

Instruction and Operating Manual

Smart Valve Positioner

SS3L / SS3R Series

SS3SL / SS3SR Series (SS316)



< Software Version V21C >

Power-Genex Ltd.



Contents

2. Overview of Structure	9
3. Specifications.....	10
3.1. Specifications for Profibus PA Communication.....	11
3.2. Specifications for Fieldbus Communication	12
4. Part Numbering System (order code)	13
4.1. Descriptions on Nameplate.....	14
5. Principle of Operation.....	14
6. Descriptions of LCD display and Buttons	15
7. Installation.....	16
7.1. Mounting onto Linear Actuator	16
7.1.1. Installation of Follower Guide.....	16
7.1.2. Installation of Feedback Lever and Mounting Bracket	16
7.1.3. Mounting onto Cast Yoke or Pillar Yoke	17
7.1.4. Mounting onto Other Kind of Cast Yoke	17
7.1.5. Mounting on Diaphragm Actuator	18
7.1.6. Installation of Feedback Pin Follower Guide	18
7.1.7. Standard Installation	19
7.2. Mounting onto Rotary Actuator	20
7.2.1. The SS3R positioner supports NAMUR mounting standard (VDI/VDE 3835, IEC 60534-6-2).....	20
7.2.2. Mounting with Fork Lever Type.....	22
7.2.3. Position of Fork Lever.....	22
7.2.4. Re-assembling Multi-size Bracket according to Rotary Actuator	23
8. Air Connections.....	24
8.1. SS3L (linear type).....	24
8.2. SS3R (rotary type).....	24
9. Electrical Connections.....	25
9.1. Terminal Block.....	25
9.2. Measuring Output Signal	26
9.2.1. With mA loop calibrator	26
9.2.2. With multi-meter	26
9.3. Earthing.....	26
9.4. Wiring Alarm Limits.....	27
9.5. HART Connection	27
9.6. Profibus PA / Fieldbus Connection	27
9.7. Wiring SPDT Micro Switches	28
9.8. Setting Micro Switches	28
10. Quick Auto-Calibration	29
10.1. Quick Auto-Calibration	29



10.2. Checking the Ambient Temperature.....	29
11. Description of Parameters Flow.....	30
11.1. Diagram of Parameters	30
11.2. Main Parameters	31
11.3. Parameters	32
11.3.1. Main Parameters.....	32
11.3.2. CTRL - Parameters (speed control adjustment).....	32
11.3.3. SUB - Parameter	32
11.4. Setting of Main Parameters	33
11.4.1. [LOCK] LOCK ON / OFF.....	33
11.4.2. [DISP] Display Mode.....	33
11.4.3. [MAN] Manual Mode (default: 0).....	34
11.4.4. [MON] Monitor Mode	34
11.4.5. [AUTO] Auto-Calibration Mode.....	35
11.4.6. [TEST] Self-Test Mode	36
11.5. Parameters Flow Diagram.....	37
11.5.1. [INPU] Change of Input signal (default: 4-20mA)	38
11.5.2. [R/DA] Selection of Direct Acting (DA) or Reverse Acting (RA) (default: RA)	38
11.5.3. [L/EQ] Selection of Linear, E.Q%, Quick Open or User Set (default: Linear)	38
11.5.4. [SPAN] Span Adjustment (default: 100).....	40
11.5.5. [ZERO] Zero Adjustment (default: 0).....	40
11.5.6. [PID] PID-Gain.....	41
11.5.7. [CTRL] Control Speed Adjustment.....	42
11.5.8. [SUB] SUB Parameter.....	45
12. Maintenance / Service.....	52
12.1. Preliminary Check Points.....	52
12.1.1. Voltage.....	52
12.1.2. Electrical Connections.....	52
12.1.3. Pneumatic Connections (see 8.1, 8.2).....	52
12.1.4. Supply Air Quality.....	52
12.2. Module Parts.....	52
12.3. Re-setting of Potentiometer (spare part No. 14a, 14b).....	52
13. Troubleshooting.....	54
13.1. Error Codes and Recommended Actions	54
14. Spare Parts.....	55
14.1. SS3 Parts	55
14.2. List of Spare Parts.....	56
15. Dimensions	57
15.1. SS3L (linear type).....	57
15.2. SS3R (rotary type).....	58



1-1 Safety Instructions

These safety instructions are intended to prevent hazardous situations and/or equipment damage. These instructions indicate the level of potential hazard with the labels of “**Caution**,” “**Warning**” or “**Danger**.” They are all important notes for safety and must be followed in addition to International Standards (IEC) ^{Note 1)}, and other safety regulations.

Note 1) IEC 60079-0 : 2007 EN 60079-0 : 2009
 IEC 60079-1 : 2007 EN 60079-1 : 2007

	Caution	Caution indicates a hazard with a low level of risk which, if not avoided, could result in minor or moderate injury.
	Warning	Warning indicates a hazard with a medium level of risk which, if not avoided, could result in death or serious injury.
	Danger	Danger indicates a hazard with a high level of risk which, if not avoided, will result in death or serious injury.



Warning

1. The compatibility of the product is the responsibility of the person who designs the equipment or decides its specifications.

Since the product specified here is used under various operating conditions, its compatibility with specific equipment must be decided by the person who designs the equipment or decides its specifications based on necessary analysis and test results. The expected performance and safety assurance of the equipment will be the responsibility of the person who has determined its compatibility with the product. This person should also continuously review all specifications of the product referring to its latest catalogue information, with a view to giving due consideration to any possibility of equipment failure when configuring the equipment.

2. Only personnel with appropriate training should operate machinery and equipment. The product specified here may become unsafe if handled incorrectly.

The assembly, operation and maintenance of machines or equipment including our products must be performed by an operator who is appropriately trained and experienced.

3. Do not service or attempt to remove product and machinery/equipment until safety is confirmed.

1. The inspection and maintenance of machinery/equipment should only be performed after measures to prevent falling or runaway of the driven objects have been confirmed.
2. When the product is to be removed, confirm that the safety measures as mentioned above are implemented and the power from any appropriate source is cut, and read and understand the specific product precautions of all relevant products carefully.
3. Before machinery/equipment is restarted, take measures to prevent unexpected operation and malfunction.

4. Contact POWER-GENEX beforehand and take special consideration of safety measures if the product is to be used in any of the following conditions.

1. Conditions and environments outside of the given specifications, or use outdoors or in a place exposed to direct sunlight.
2. Installation on equipment in conjunction with atomic energy, railways, air navigation, space, shipping, vehicles, military, medical treatment, combustion and recreation, or equipment in contact with food and beverages, emergency stop circuits, clutch and brake circuits in press applications, safety equipment or other applications unsuitable for the standard specifications described in the product catalogue.
3. An application which could have negative effects on people, property, or animals requiring special safety analysis.
4. Use in an interlock circuit, which requires the provision of double interlock for possible failure by using a mechanical protective function, and periodical checks to confirm proper operation.

4. Do not open when an explosive gas and dust atmosphere may be present.



1-2 Safety Instructions



Caution

1. The product is provided for use in manufacturing industries.

The product herein described is basically provided for peaceful use in manufacturing industries. If considering using the product in other industries, consult POWER-GENEX beforehand and exchange specifications or a contract if necessary. If anything is unclear, contact your nearest sales branch.

Limited warranty and Disclaimer/Compliance Requirements

The product used is subject to the following "Limited warranty and Disclaimer" and "Compliance Requirements". Read and accept them before using the product.

Limited warranty and Disclaimer

1. The warranty period of the product is 1 year in service or 1.5 years after the product is delivered. Note 2)

Also, the product may have specified durability, running distance or replacement parts. Please consult your nearest sales branch.

2. For any failure or damage reported within the warranty period which is clearly our responsibility, a replacement product or necessary parts will be provided. This limited warranty applies only to our product independently, and not to any other damage incurred due to the failure of the product.

3. Prior to using POWER-GENEX products, please read and understand the warranty terms and disclaimers noted in the specified catalogue for the particular products.

Note 2) Vacuum pads are excluded from this 1 year warranty.

A vacuum pad is a consumable part, so it is warranted for a year after it is delivered.

Also, even within the warranty period, the wear of a product due to the use of the vacuum pad or failure due to the deterioration of rubber material are not covered by the limited warranty.

Compliance Requirements

1. The use of POWER-GENEX products with production equipment for the manufacture of weapons of mass destruction (WMD) or any other weapon is strictly prohibited.

2. The exports of POWER-GENEX products or technology from one country to another are governed by the relevant security laws and regulations of the countries involved in the transaction. Prior to the shipment of a POWER-GENEX product to another country, assure that all local rules governing that export are known and followed.



1-3 Precautions

Be sure to read before handling.

Operation



Warning

1. Do not operate the positioner outside the specified range as this may cause problems. (Refer to the specifications.)
2. Design the system to include a safety circuit to avoid the risk of danger should the positioner suffer failure.
3. Be sure that exterior lead-in wiring to the terminal box is based on the guidelines for explosion-protection of manufactory electric equipment when being used as a flame proof, explosion proof construction.
4. Do not remove terminal cover in a hazardous location while the power is on.
5. Covers for the terminal and body should be in place while operating.
6. When using as an intrinsically safe explosion-proof product, do not wire in a hazardous location while the power is on.



Caution

1. Do not touch the actuator or valve's oscillating section when supply pressure has been added, as this is dangerous.
2. Make sure fingers do not get caught when mounting and aligning the cam.
Cut off the pressure supply and always release the compressed air inside the positioner and actuator before performing this work.
3. Always use with the body cover unit mounted.
Moreover, the positioner may not meet degrees of protection IP66 depending on the body cover mounting conditions. In order to meet degrees of protection IP66, tighten threads using the proper tightening torques (2.8 to 3.0 N·m).
4. Always flush the pipe's inside before piping to ensure foreign objects such as machining chips do not enter the positioner.
5. The actuator opening may become unstable when using the booster relay.
6. Always use a ground connection to prevent noise from the input current and to prevent damage because of static electricity.
7. Use the pressure reading on the supplied pressure gauge as an indication.
8. The supplied pressure gauge's needle will malfunction if the pressure supply to the internal mechanism or positioner freezes. Ensure that the pressure gauge's internal parts do not freeze if using the pressure gauge in an operating environment with an ambient temperature of less than 0°C.

For users



Caution

1. Assemble, operate and maintain the positioners after reading the operation manual thoroughly and understanding the content.



1-4 Precautions

Be sure to read before handling.

Handling



Caution

1. Avoid excessive vibration or impact to the positioner body and any excessive force to the armature, as these actions may cause damage to the product. Handle carefully while transporting and operating.
2. If being used in a place where vibration occurs, using a binding band is recommended to prevent broken wires because of the vibration.
3. When exposed to possible moisture invasion, please take the necessary measures. For example, if the positioner is left onsite for long periods, a plug should be put in the piping port and a body cover unit fitted to avoid water penetration.
Take measures to avoid dew condensation inside the positioner if exposed to high temperature and humidity. Take enough measures against condensation especially when packing for export.
4. Keep magnetic field off the positioner, as this affects its characteristics.

Air Supply



Caution

1. Use only dehumidified and dust extracted clean compressed air as the air supply.
2. Use only dehumidified and dust extracted clean compressed clean air as the positioner contains extrafine orifices such as restrictor and nozzle.
Do not use a lubricator.
3. Do not use compressed air containing chemicals, organic solvents, salinity or corrosive gases, as this may cause malfunction.
4. When operating below the freezing point, protect the positioner from freezing.

Operating Environment



Caution

1. Do not operate in locations with an atmosphere of corrosive gases, chemicals, sea water, or where these substances will adhere to the regulator.
2. Do not operate out of the indicated operation temperature range as this may cause damage to electronic parts and seal materials to deteriorate.
3. Do not operate in locations where excessive vibration or impact occurs.
4. If the body cover is being installed in a place where the body cover is exposed to direct sunlight, the use of a standard body cover without the LCD window is recommended.



1-5 Precautions

Be sure to read before handling.

Maintenance



Warning

1. After installation, repair or disassembly, connect compressed air and conduct tests to confirm appropriate function and leakage.

Do not use the positioner when noise from the bleeder sounds louder compared with the initial state, or when it does not operate normally. If these occur, check immediately if assembled and mounted correctly.

Never modify electrical construction to maintain explosion-proof construction.



Warning-Potential electrostatic charging hazard

1. The non-metallic parts incorporated in the enclosure of this equipment may generate an ignition capable level of electrostatic charge. Therefore particularly when it used for applications that specifically require Group IIC, EPL Ga equipment, the equipment shall not be installed in a location where the external conditions are conducive to the build-up of electrostatic charge on such surfaces. Additionally, the equipment shall only be cleaned with a damp cloth.
2. The enclosure contains aluminium and is considered to present a potential risk of ignition by impact or friction. Care must be taken during installation and use to prevent impact or friction. Particularly, it must not be used for applications that specifically require EPL Ga equipment.



Caution

1. The insulation between an intrinsically safe circuit and a frame of the equipment is not capable of withstanding a 500V dielectric strength test as defined in Cl.6.3.12 of EN 60079-11:2007. This shall be taken into account during installation.
2. the earthing of enclosure is necessary to maintain Intrinsic Safety because the insulation between an intrinsically safe circuit and a frame of the equipment is not capable of withstanding a 500V dielectric strength test. There are two earthing points on the equipment. One is provided as an internal earthing point inside rear cover of the equipment for attaching of a cable screen. The other is provided as an external earthing point on the left side of the enclosure. Their cross-sectional areas should be capable of carrying the maximum possible current of the equipment. (Generally, an insulated wire having a cross-sectional area of at least 4mm^2 is recommended) The cable should be fitted with a split ring lock washer to minimize the risk of self-loosening and is of suitable construction for securing of conductors of cross sections up to 4mm^2 .

2. Overview of Structure

This product consists of the following parts.

- Electronic card comprised of microprocessor, HART modem and LCD
- Potentiometer for position feedback
- Pilot valve, Torque motor, Pressure gauge and block

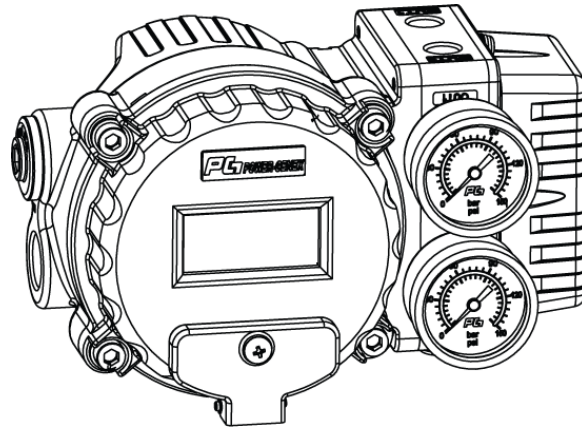

The followings are descriptions of internal parts without cover.

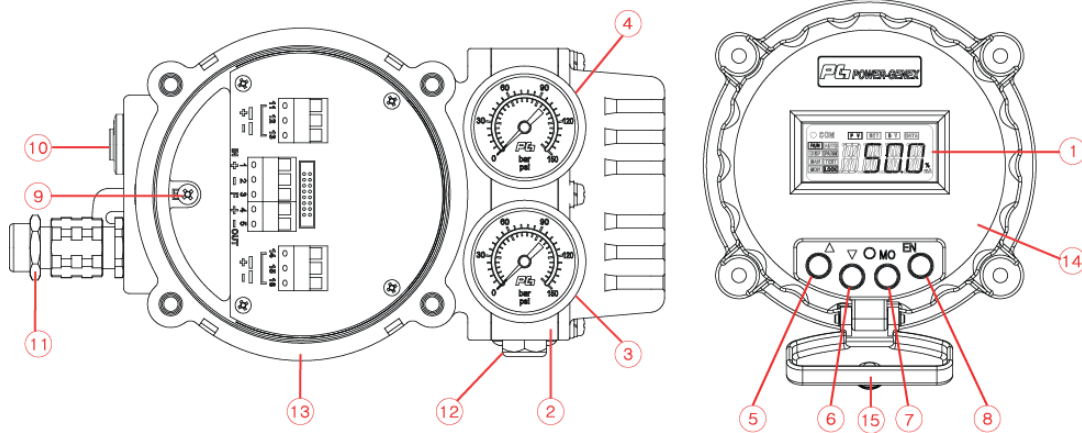

1	LCD	7	MO, Mode button	13	Positioner body
2	Gauge block	8	ENT, button	14	Positioner cover
3	Supply air gauge	9	Ground	15	Button cover
4	Out 1 gauge	10	Blind plug (or cable gland)		
5	▲ UP, Up button	11	Cable gland (or Blind plug)		
6	▼ DN, Down button	12	Air venting hole		

3. Specifications

Input signal	4 - 20 mA @ 24 VDC	
Min. / Max. current	3.6 mA / 50mA	
Communication	HART / Profibus PA / Foundation Fieldbus	
Operating angle/ stroke	Linear type: 5 - 130mm * Rotary type: 25 - 120°	
Supply air pressure	1.4 - 7.0 bar (20 - 100 psi)	
Output pressure range	0 - 100% of supply air	
Air flow capacity	80 l/min = 4.8 Nm ³ /h = 2.8 scfm (Sup = 1.4 bar) 233 l/min = 14 Nm ³ /h = 8.2 scfm (Sup = 6 bar)	
Air consumption	2.8 l/min = 0.17 Nm ³ /h = 0.1 scfm (Sup = 1.4 ~ 6 bar)	
Characteristic	Linearity < ±0.3% F.S Sensitivity < 0.2% F.S Hysteresis < 0.2% F.S Repeatability < 0.2% F.S	
Operating characteristic	Linear, EQ%, Quick open, User set (17 points)	
LCD display	4-digit	
Response speed	1 - 1000 (Min. 1, Max. 1000)	
Scan time	2 ms	
Shut-off value	0 - 10%	
Valve action	Direct acting (DA) / reverse acting (RA)	
Operating temperature	-30°C ~ +75°C (-22 ~ +167°F)	
Pneumatic connections	Rc 1/4 or NPT 1/4	NPT 1/4
Electrical connections	G 1/2, NPT 1/2 or M20 x 1.5	NPT 1/2
Explosion proof / protection class	ATEX / IECEx-certified explosion proof Ex d IIC T6, IP66	
Body material / painting	Aluminum die-cast	Stainless Steel 316
Weight	2.8 kg	6.5 kg

With Communication

Communication	-	HART	PROFIBUS	Foundation Fieldbus
Input signal / Bus voltage	4 – 20 mA @ 24 VDC		9 – 32 VDC	
Min. / Max. Current	3.6 mA / 50mA		-	
Current Consumption	-		15 mA	16 mA
Voltage drop (impedance)	8.9 VDC (445Ω @ 20mA)	9.4 VDC (470Ω @ 20mA)	-	

* For more than 200mm stroke on request

3.1. Specifications for Profibus PA Communication

Profiles	PROFIBUS Profile for Process Control Devices Version 3.02
Block types	1 AI Function Block 1 AO Function Block 2 DI Function Block 1 Transducer Block 1 Physical Block
Physical layer	In compliance with IEC 61158-2
Transmission rate	31.25 kbit/s
Supply voltage	Bus-powered : 9 ~ 32 VDC
Max. permissible voltage	35 VDC
Power consumption	15 mA
Physical device tag	SSPA
PNO ID number	0x0E19
Bus address	Between 0 and 126, default bus address 126
Certification No.	Z01802
Revision	1.0;SW/FW:01.00;HW:01.00
GSD	PWGX0E19.GSD, File Version: 5.0 pa139710.gsd

3.2. Specifications for Fieldbus Communication

Specification	Foundation™ Fieldbus Version 2.0
Physical layer	Model 113,121 (IEC 61158-2)
Transmission rate	31.25 kbit/s
Supply voltage	Bus-powered : 9 ~ 32 VDC
Block types	2 AI Function Block 1 AO Function Block 2 DI Function Block 1 Transducer Block 1 Physical Block
Max. execution time	AO block: 31.25 milliseconds
Supply voltage	Power feed from the fieldbus: 9 ~ 32 VDC
Max. permissible voltage	36 VDC
Power consumption	16 mA
Certificate	FF Conformance Test ITK 6.1.1
Device name	PG-SS Positioner
Dev. ID	0003460001_PG-SS_XXXXXXXX
Unit address	Between 10 and 27, default address 247
Class	LM profile 32L, 31PS
Factory default	The PG-SS Positioner is not delivered in an aligned state. To adjust the operating range and control parameters, an automatic configuration must be run on the unit. Otherwise, the transducer block remains in out-of-service mode.
Diagnostic functions	Self-diagnostics for the PG-SS Positioner hardware and software, valve diagnostics with enhanced alarm handling

4. Part Numbering System (order code)

Model classification code or ordering information or type designation or model schedule or model numbering system

			SS3	x	—	x	x	x	x	x	x	x	x				
Body Material	Aluminum			blank													
	SUS316			S													
Actuator action	Linear type			L													
	Rotary type			R													
Protection class	Flameproof (Ex d IIC T6)			F													
Feedback lever	Linear type	8 ~ 30mm stroke					A										
		8 ~ 70mm stroke					B										
		8 ~ 130mm stroke						C									
		80 ~ 200mm stroke							D								
	Rotary type	Fork lever							F								
		NAMUR shaft (direct mounting)								N							
Pressure Gauge	Not included									0							
	6 bar (90psi)										1						
	10 bar (150psi)											2					
Position feedback	Not included										N						
	Position transmitter (4~20mA output)											O					
	2 x alarm limit												L				
	2 x micro switch (SPDT)												S				
	O + L													M			
	O + S														Q		
Communication	Not included												N				
	HART communication													H			
	Profibus communication													P			
	Foundation Fieldbus														F		
Pneumatic – electrical connections	Rc 1/4 - G 1/2 (standard)														3		
	NPT 1/4 - NPT 1/2 (SUS316 Only)															4	
	Rc1/4 - M20x1.5															5	
Mounting bracket	Not included															N	
	IEC 60534-6-1 (for SS3L)																L
	IEC 60534-6-2(VDI/VDE 3845)(for SS3R)																R
Feedback pin guide	Not included																0
	Included																1

4.1. Descriptions on Nameplate

SMART VALVE POSITIONER		
Model No. :	IECEX KTL 11,0020	Ex d IIC T6 Gb
Input Signal : 4 ~ 20 mA DC	CS 12-KB2BO-0002	Ex d IIC T6
Supply Air Pressure : 1.4 ~ 7 bar	INERIS ATEX	
Operating Temp. : - 30 ~ + 75°C	CE 0080	Ex II 2G EEx d IIC T6
Serial No. :	WARNING DO NOT OPEN WHEN AN EXPLOSIVE GAS AND DUST ATMOSPHERE MAY BE PRESENT.	
POWER-GENEX LTD. Made in Korea		

.. MODEL NUMBER

Model number and options are described.

.. INPUT SIGNAL

Current input signal is described. 4~20mA current is used. Inquire the head office or the agents if other special input signal is required.

.. Supply Air Pressure: 1.4 ~ 7bar(20 ~ 101psi)

.. SERIAL NUMBER / DATE: A serial number and a manufacturing date for tracking are described.

.. Certificate No

CE XXXX / INERIS ATEX XXXX / IECEX KTL 11.0020X / 11-KB2BO-XXXX

.. Code : Ex d IIC T6 Gb (Temp. -30 to +75°C)

.. WARNING

1. Do not open when an explosive gas and dust atmosphere may be present

5. Principle of Operation

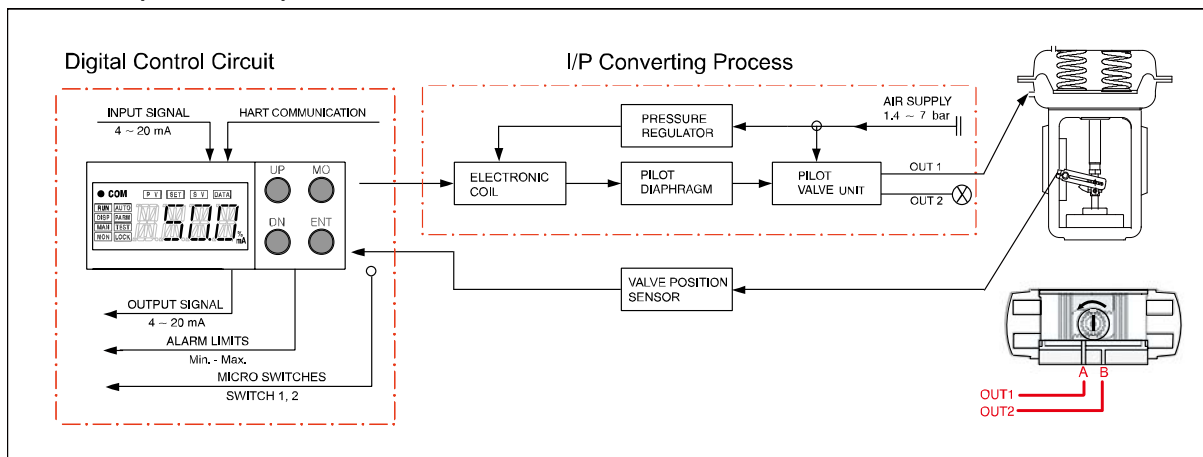

If 4-20 mA input signal is supplied, the micro-processor compares input signal with position feedback and sends control signal to the I/P converting module. Pneumatic signal from the I/P converting module operates the valve and the valve stays at the desired position.

6. Descriptions of LCD display and Buttons

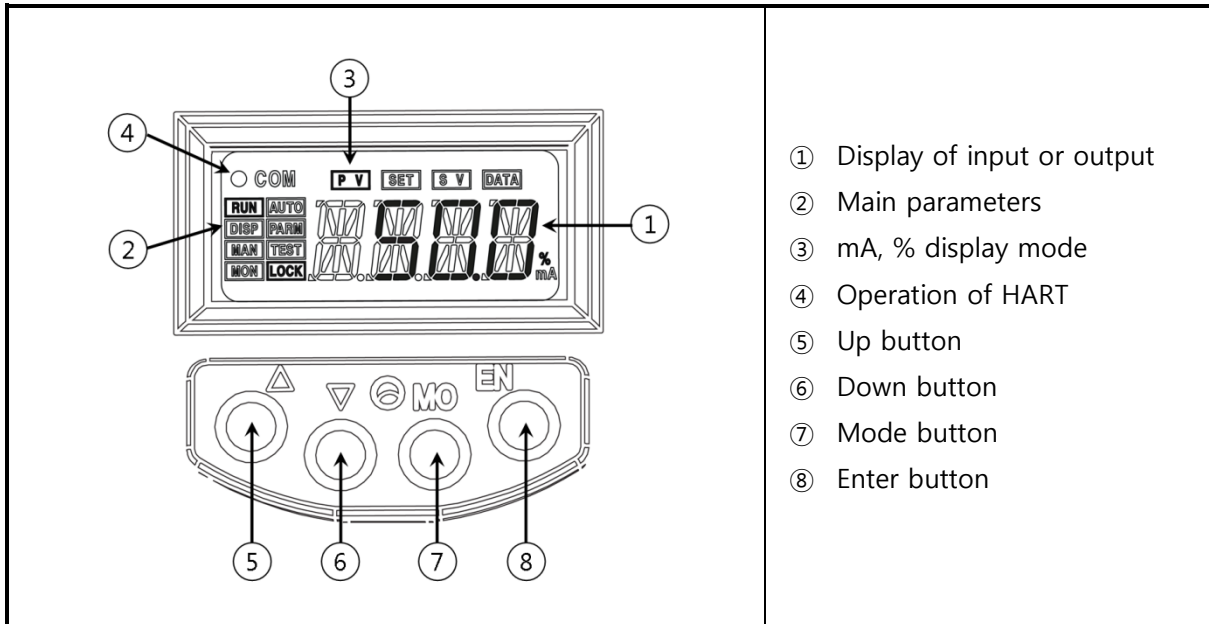

- ① Display of input or output
- ② Main parameters
- ③ mA, % display mode
- ④ Operation of HART
- ⑤ Up button
- ⑥ Down button
- ⑦ Mode button
- ⑧ Enter button

Press "Mode" button for 5 seconds	• Quick auto-calibration
Press "Up(▲)" button for 5 seconds	• GROP-gain adjustment
Press "Down(▼)" button for 5 seconds	• Span adjustment
Press "Enter" button	• Ambient temperature (°C)

① Display of input or output	• mA, %
② Main parameters	<p style="text-align: center;"> MODE ↔ RUN ↔ DISP ↔ MAN ↔ MON ↔ AUTO ↕ ↘ LOCK ↔ TEST ↔ PARM ↙ ↗ </p>
③ Display mode	• Selection of mA, % or in reverse way with values shown (Ex. Reverse : 20% shown → 80% shown)
④ HART communication	• HART communication
⑤ Up (▲)	• UP button
⑥ Down (▼)	• DOWN button
⑦ MO (Mode)	• Selection of running mode • Selection of parameter group or parameter
⑧ ENT(Enter)	• Save of setting values

7. Installation



Be sure to install the air filter regulator before the positioner and check a supply air pressure required to move the valve.

7.1. Mounting onto Linear Actuator

7.1.1. Installation of Follower Guide

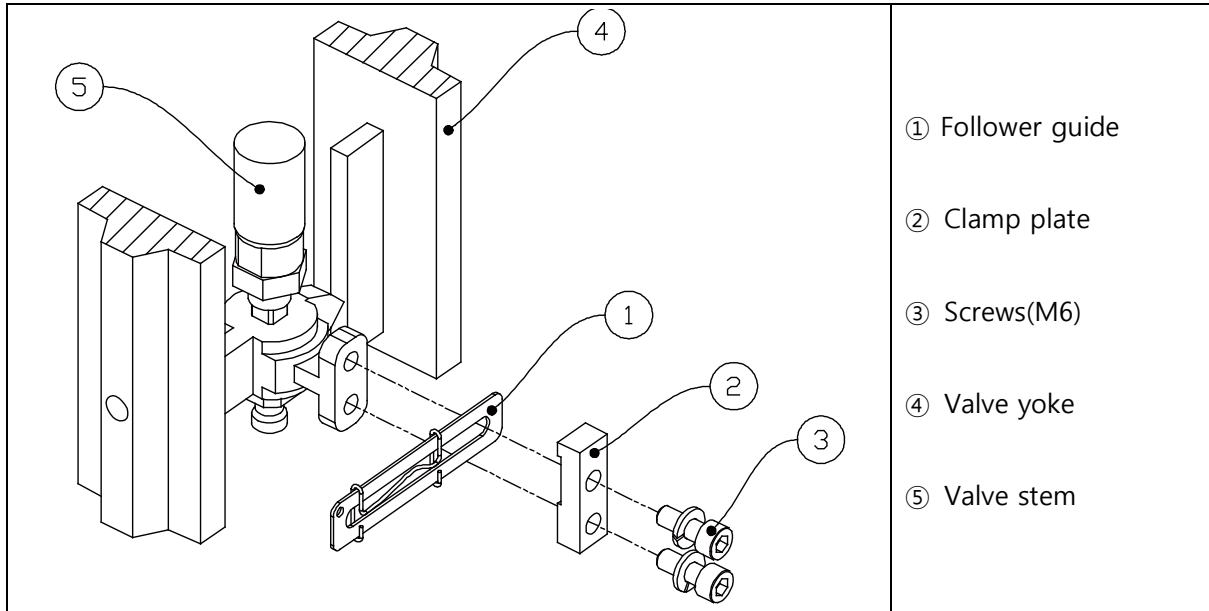

7.1.2. Installation of Feedback Lever and Mounting Bracket

Mounting bracket for SS2L positioner is designed to support IEC 60534-6-1.

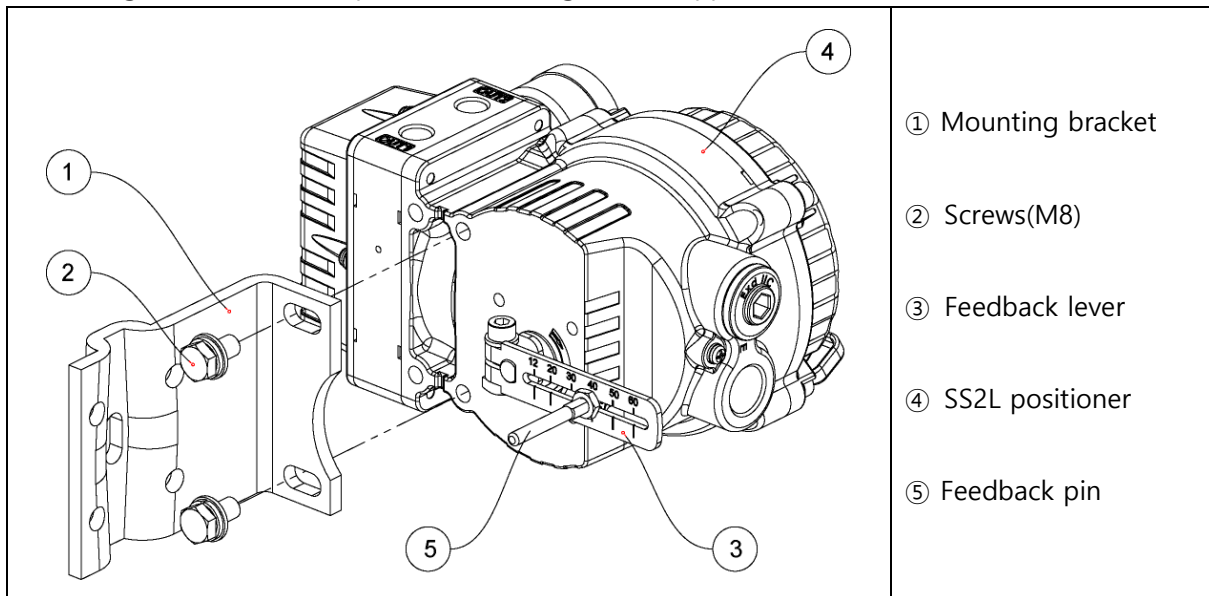

7.1.3. Mounting onto Cast Yoke or Pillar Yoke

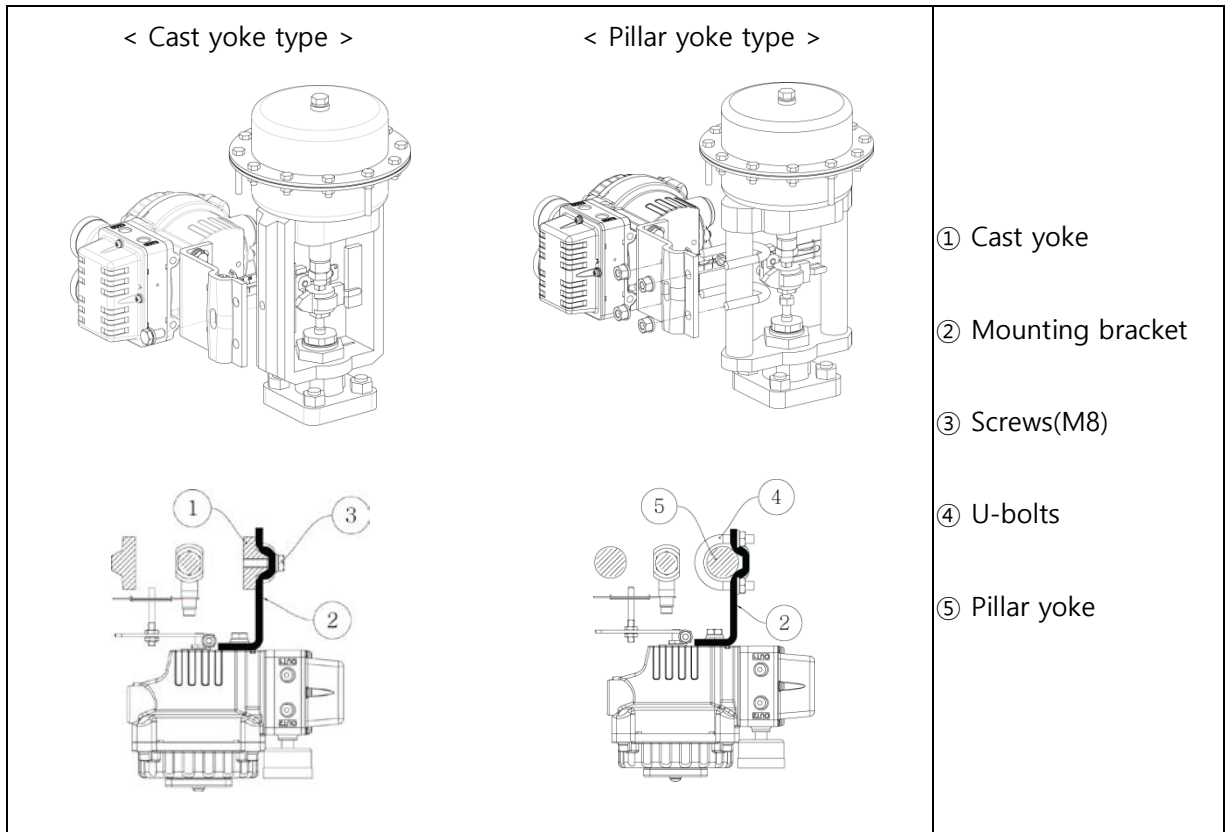

7.1.4. Mounting onto Other Kind of Cast Yoke

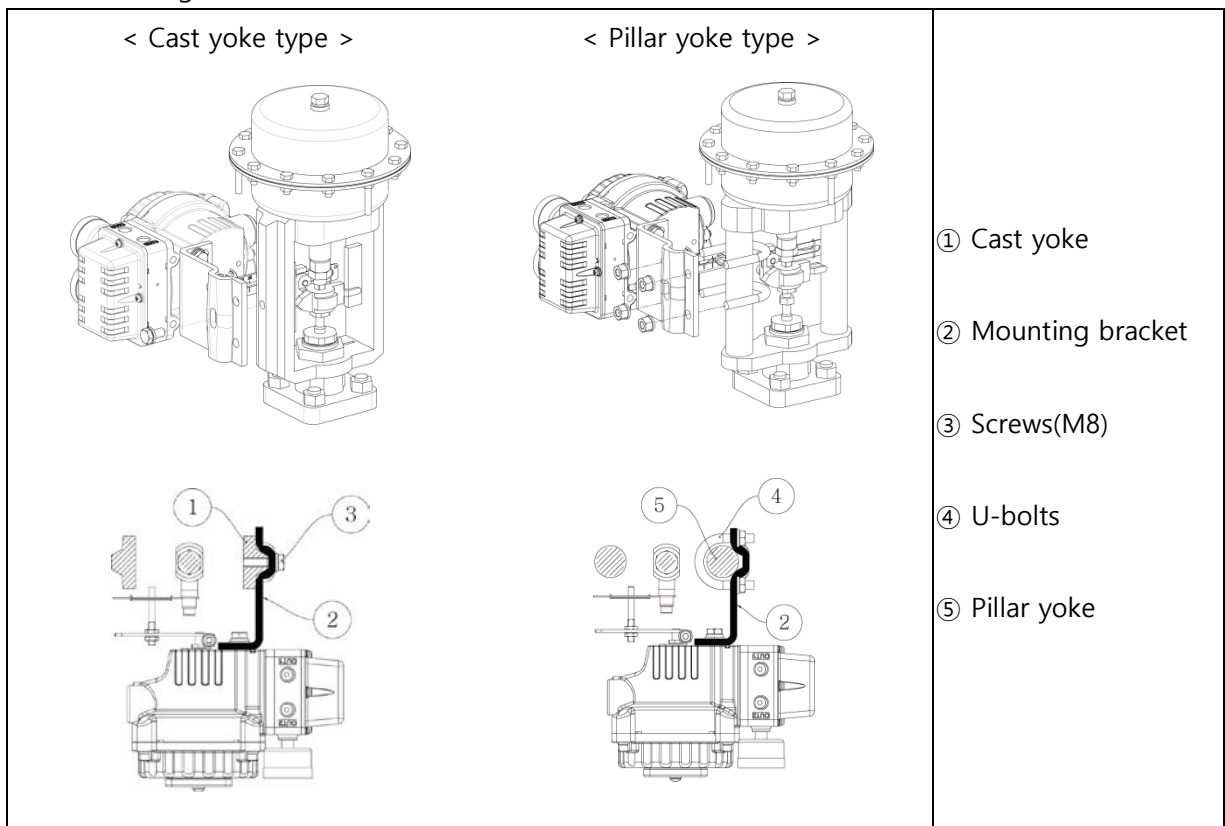

7.1.5. Mounting on Diaphragm Actuator

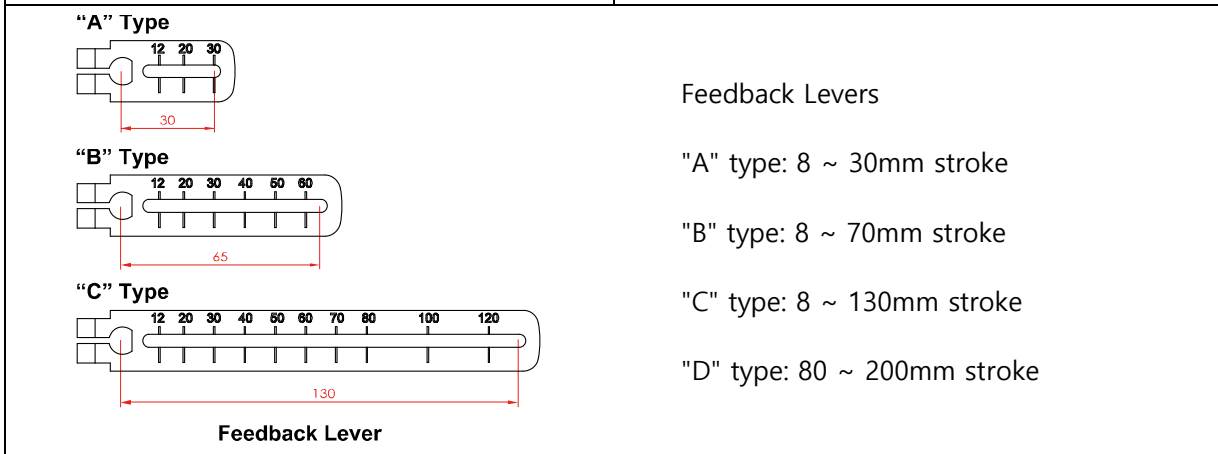
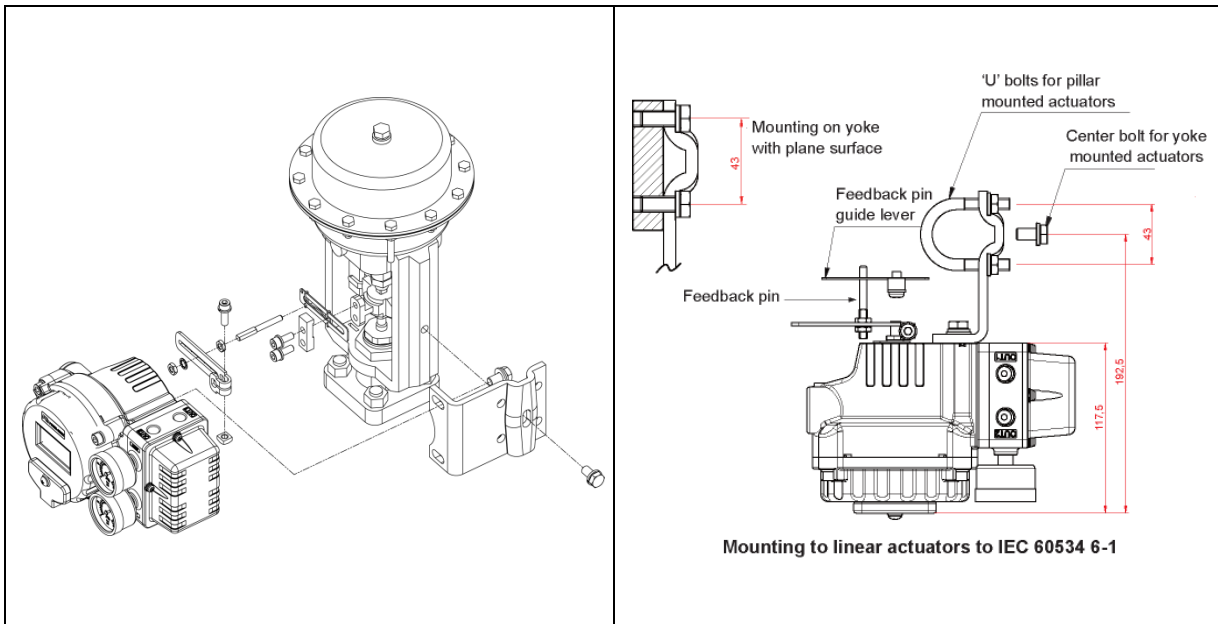

7.1.6. Installation of Feedback Pin Follower Guide

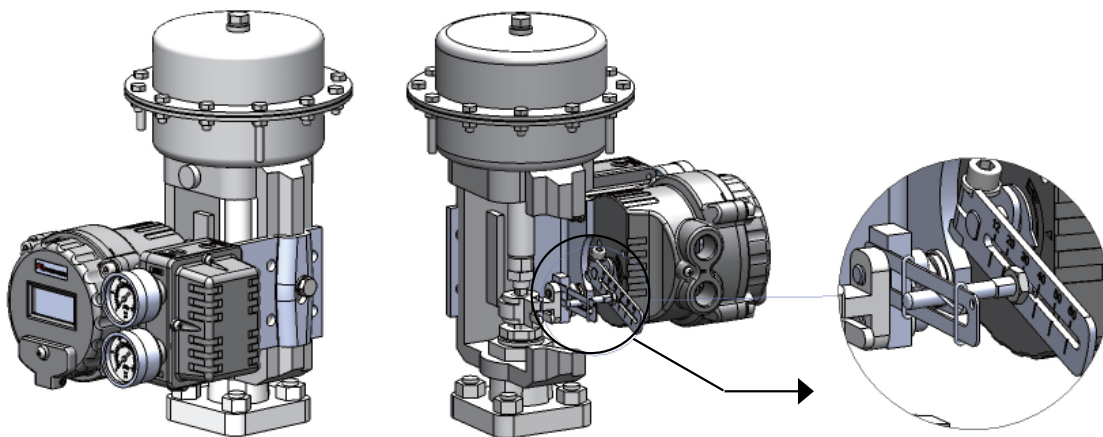

7.1.7. Standard Installation

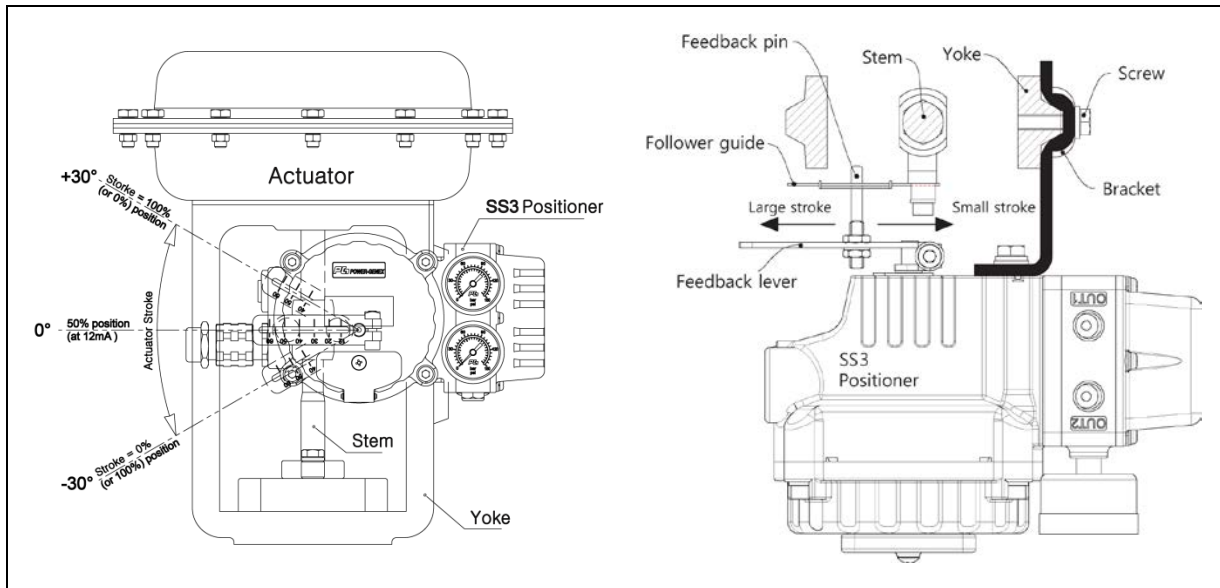

- ① Supply air directly to the actuator, adjust the air filter regulator and set air when the valve reaches to 50% stroke.
- ② Install the feedback pin at around 30% higher point of the stroke indicated on the feedback lever than the required stroke of the control valve and fix with a screw tightly. For example,

Control valve stroke	Stroke indicated on feedback lever
15mm	20mm
20mm	25mm
30mm	40mm

- ③ Install the feedback lever horizontally at 50% stroke position.
- ④ If the feedback lever is not installed horizontally, move the mounting bracket up and down little by little so that it can be positioned horizontally.
- ⑤ Fix the mounting bracket with screws (M8).
- ⑥ Connect air lines between the SS3L positioner and the actuator and supply air to the positioner and perform auto-calibration by pushing Mode button for 5 seconds.
- ⑦ The operating angle from 0% to 100% stroke should be within the range of $\pm 30^\circ$. In case of the over-range of 30° , move the valve stem pin to left or right and make the SS3L positioner stay within the operating angle of $\pm 30^\circ$.



Make sure that the SS3L positioner works within the operating range of $\pm 30^\circ$. See the below pictures. Otherwise, the error message of 'MONT' appears on LCD and the auto-calibration process fails. Take action as advised in the above ⑦ and get the SS3L positioner feedback lever positioned horizontally at 12mA (50%).

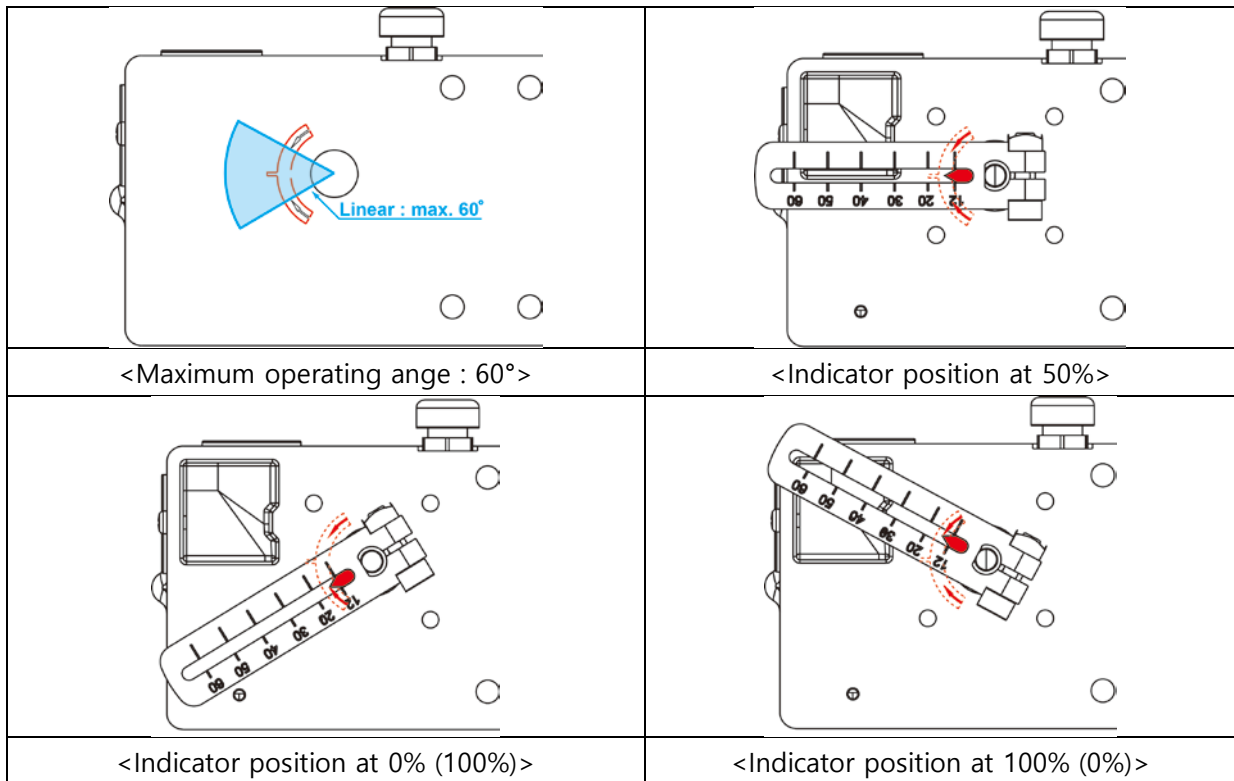

7.2. Mounting onto Rotary Actuator

7.2.1. The SS3R positioner supports NAMUR mounting standard (VDI/VDE 3835, IEC 60534-6-2).

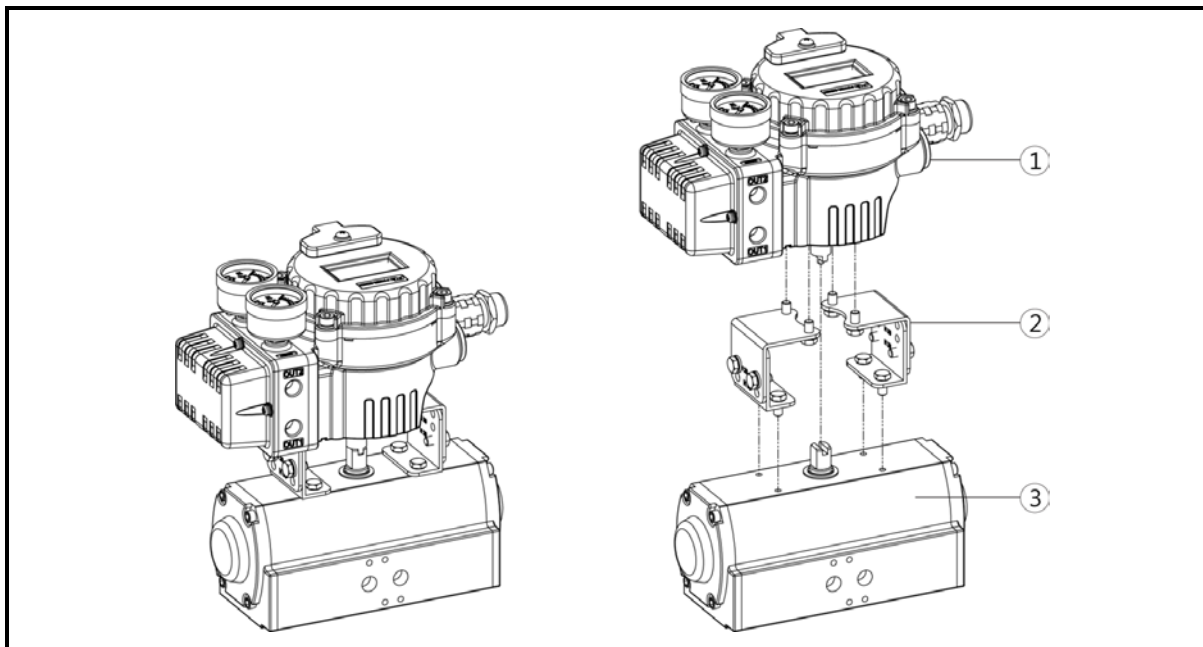

① SS3R positioner

② Multi-size bracket

③ Rotary pneumatic actuator

- ① Assemble the multi-size bracket to the SS3R positioner with 4 pcs M6 screw. The multi-size bracket is assembled for 80x30x20mm as standard at the factory. If you have other size bracket, see '7.2.4 Re-assembling Multi-size Bracket according to Rotary Actuator'.
- ② Mount the SS3R positioner onto the rotary pneumatic actuator with 4 pcs M5 screw.
- ③ Connect air lines between the SS3R positioner and the rotary pneumatic actuator.
- ④ Perform auto-calibration by pushing MODE button for 5 seconds.



Make sure that the SS3R positioner works within the operating range indicated on the bottom. See the below pictures. Otherwise, the error message of 'MONT' appears on LCD and the auto-calibration process fails.

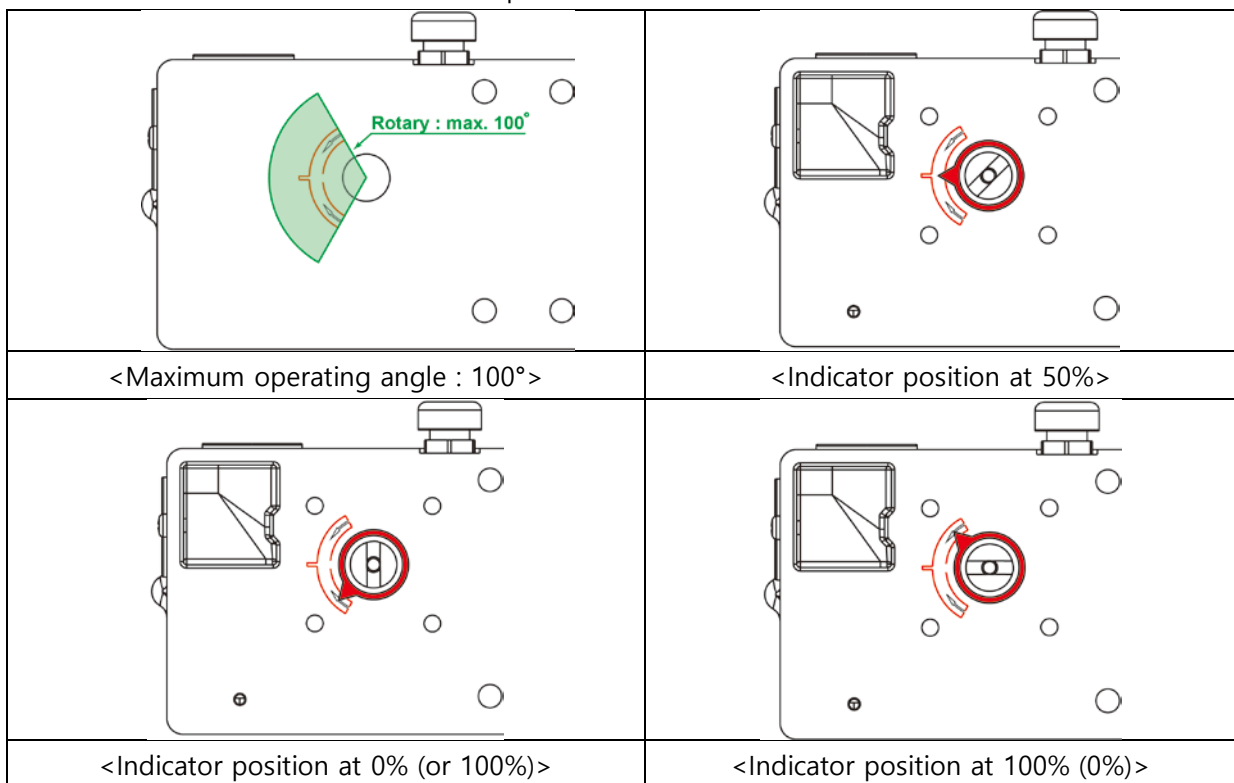

7.2.2. Mounting with Fork Lever Type

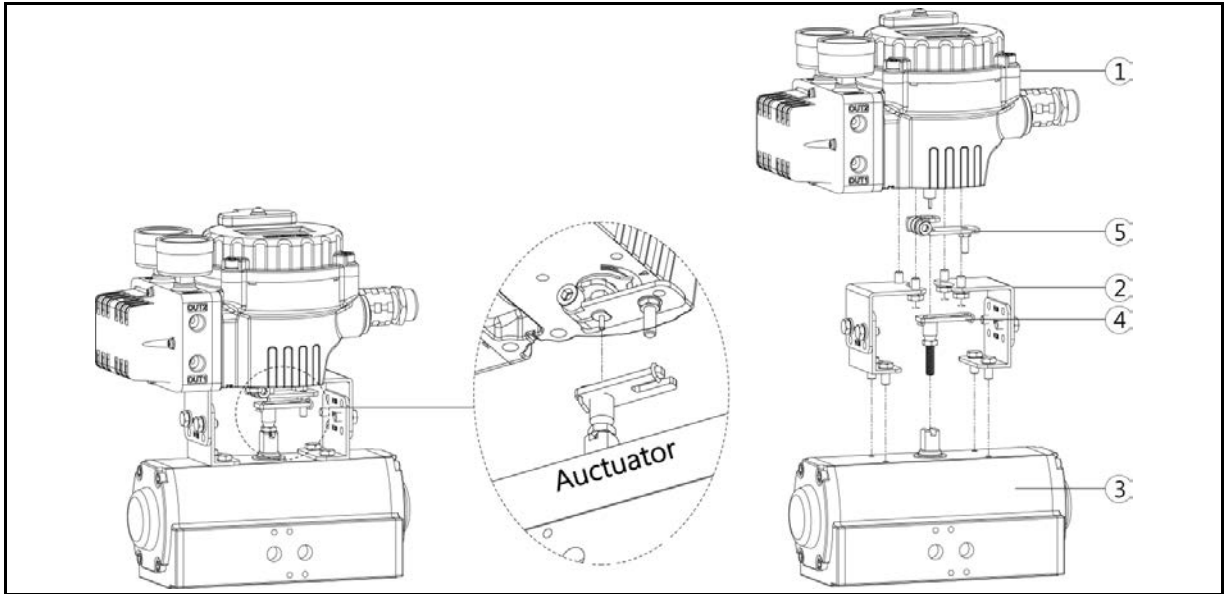

① SS2R positioner

② Multi-size bracket

③ Rotary pneumatic actuator

④ Fork lever

⑤ Positioner feedback lever

7.2.3. Position of Fork Lever

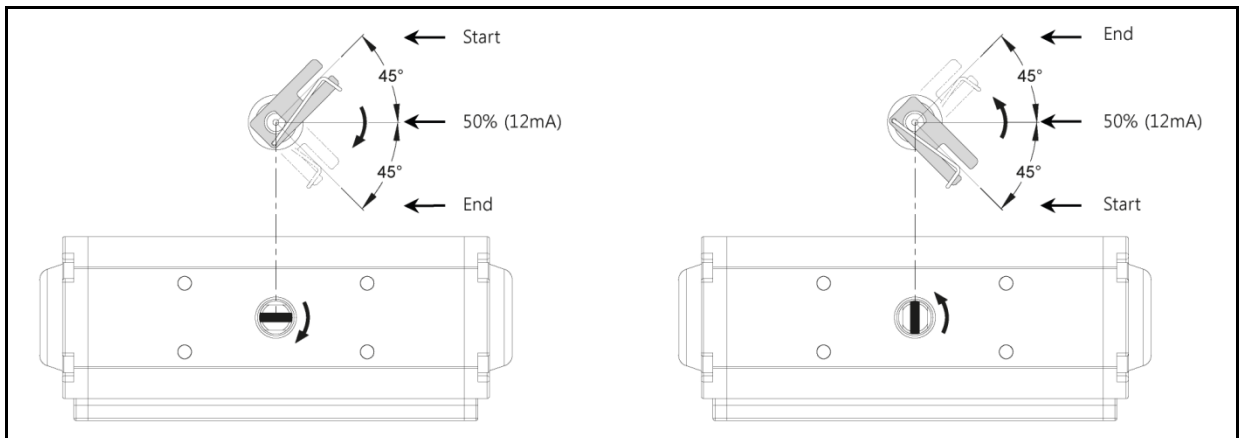

Clockwise movement

Counter-clockwise Movement

7.2.4. Re-assembling Multi-size Bracket according to Rotary Actuator

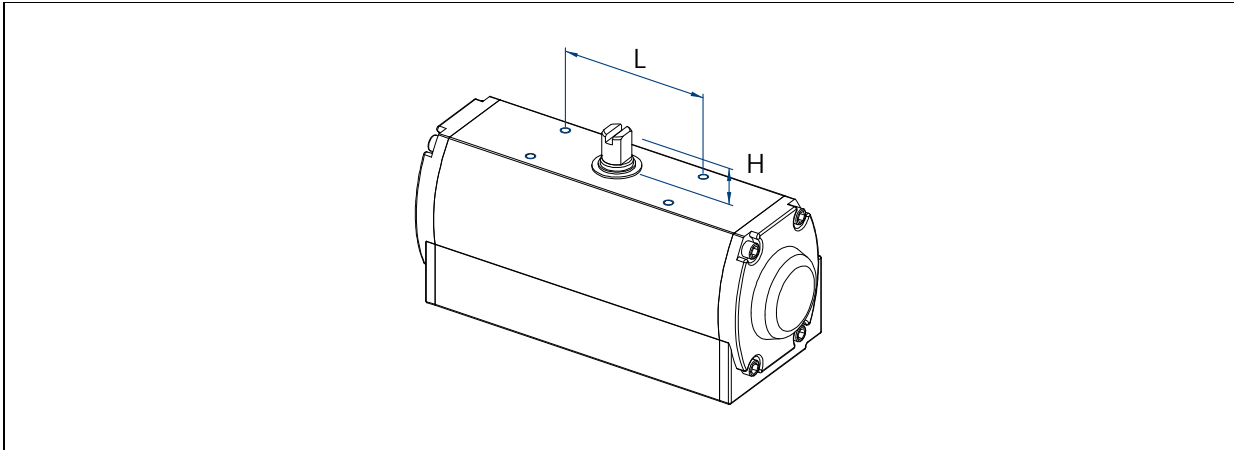

L (mm)	H (mm)		L (mm)	H (mm)	
80	20		130	20	
80	30		130	30	
80	50		130	50	



Check L and H on the actuator and re-assemble the multi-size bracket to fit your actuator mounting configuration.

8. Air Connections



- ① Be sure to install the air filter regulator before the positioner.
- ② Supply air should not contain water, oil or moisture.
- ③ It is recommended to set a supply air pressure 10% higher than the actual operating pressure of the actuator.

8.1. SS3L (linear type)

Direct Acting (DA)		Reverse Acting (RA)	
DA 1 As the input signal increases, Valve stem moves downwards Actuator : DA	 OUT2 must be plugged	RA 1 As the input signal increases, Valve stem moves upwards Actuator : RA	 OUT2 must be plugged
DA 2 As the input signal increases, Valve stem moves downwards Actuator : DA	 OUT1 must be plugged	RA 2 As the input signal increases, Valve stem moves upwards Actuator : RA	 OUT1 must be plugged
DA 3 As the input signal increases, Valve stem moves downwards		RA 3 As the input signal increases, Valve stem moves upwards	

8.2. SS3R (rotary type)

Spring Return	Double Acting	Double Acting
 Actuator : RA OUT2 must be plugged	 Actuator : RA	 Actuator : DA
As the input signal increases, Actuator shaft rotates counter-clockwise	As the input signal increases, Actuator shaft rotates counter-clockwise	As the input signal increases, Actuator shaft rotates clockwise

	Spring Return	Double Acting
Reverse Acting	Out 1 : piped, Out2 : plugged	Out 1 : piped to Actuator port A, Out2 : piped to Actuator port B
Direct Acting	Out 1 : plugged, Out2 : piped	Out 1 : piped to Actuator port B, Out2 : piped to Actuator port A

9. Electrical Connections



- ① Be sure to supply the rated voltage and current stated on this manual. Otherwise, it may cause a serious damage or malfunctions.
- ② Check polarity of + and – exactly and connect wires.
- ③ When it is necessary to open the positioner cover at a humid place, more attention is required. It may cause a serious damage or malfunctions.
- ④ The smart valve positioner SS3 positioner is certified to ATEX / IECEx explosion proof Exd IIC T6.

Take extra care when handling the positioner as explosion-proof equipment.

To use as Ex d IIC T6

A) Pressure-proof packing: As shown below in the chart, use "Cable gland"

B) Metal Piping: Attach the sealant fitting bracket near the cable port.

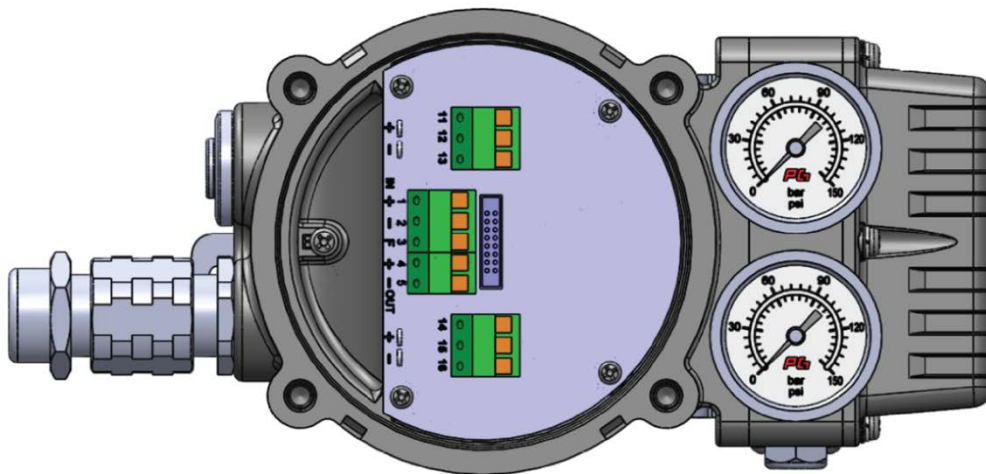

9.1. Terminal Block

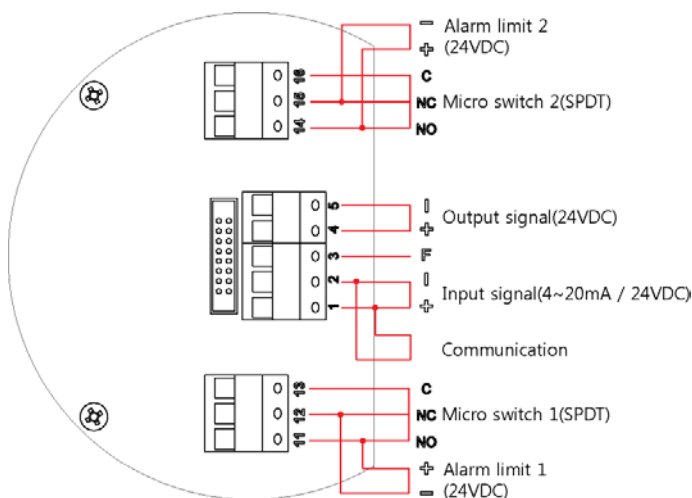

1	+	4-20mA Input signal
2	-	4-20mA Input
3		Ground
4	+	4-20mA Output signal
5	-	4-20mA Output signal
11	+	Alarm limit 1
12	-	Alarm limit 1
14	+	Alarm limit 2
15	-	Alarm limit 2
11		Micro switch 1 NO
12		Micro switch 1 NC
13		Micro switch 1 COM
14		Micro switch 2 NO
15		Micro switch 2 NC
16		Micro switch 2 COM

9.2. Measuring Output Signal

9.2.1. With mA loop calibrator

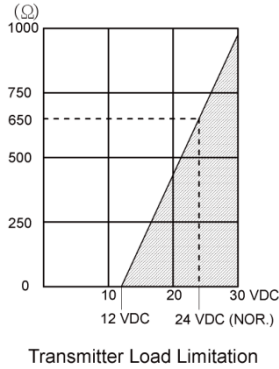
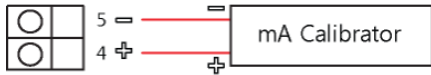

Position Transmitter Specifications	
Output signal	4 – 20mA, 2-wire
Power supply	12 – 30 VDC
Output current limit	30mA DC
Linearity	±0.75% F.S

9.2.2. With multi-meter

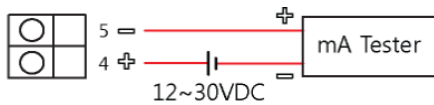

Zero and span of position feedback (4-20mA output signal) are set automatically during auto-calibration process.

9.3. Earthing

The SS3 positioner provides the internal earthing and the external earthing as shown below. Note that the SS3 positioner should be earthed for a safe usage and operation.

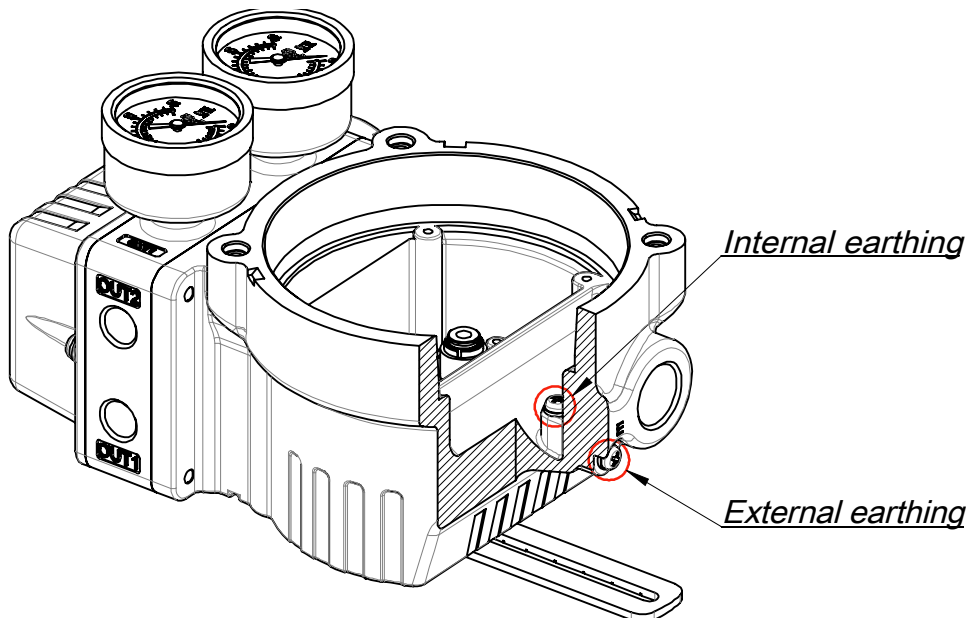

9.4. Wiring Alarm Limits

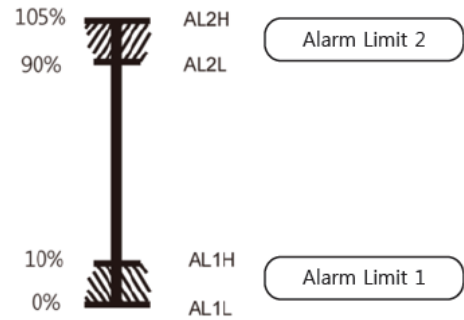
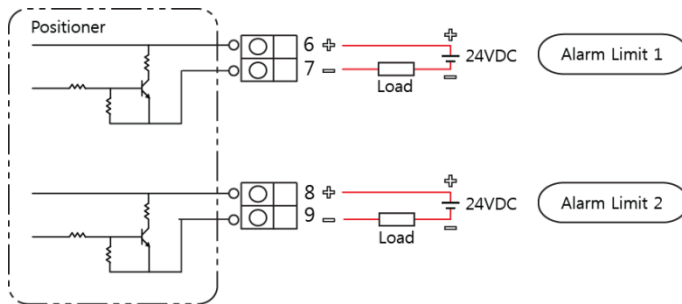

Alarm Limit Factory Setting



24VDC should be supplied for alarm limits.

9.5. HART Connection



Note that wires for HART communication should be connected to terminals No. 1 and No. 2 together with wires for input signals. For reference, there is no distinction in + and - between HART wires.

9.6. Profibus PA / Fieldbus Connection



Make sure of + and - when connecting wires.

9.7. Wiring SPDT Micro Switches

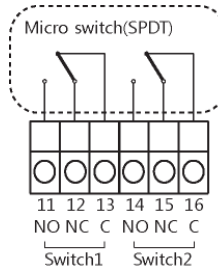
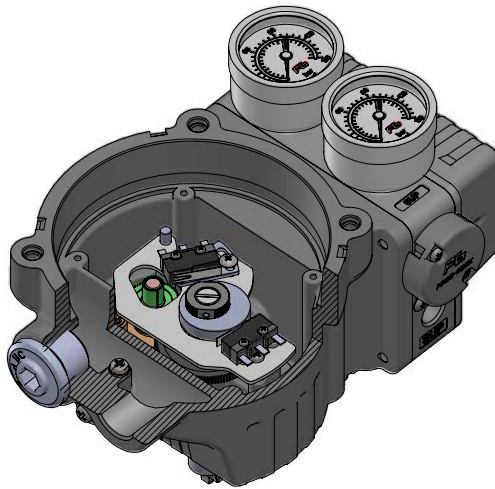

Micro Switch Specifications	
Type	SPDT
Rating code	10.1A @ 250 VAC

9.8. Setting Micro Switches

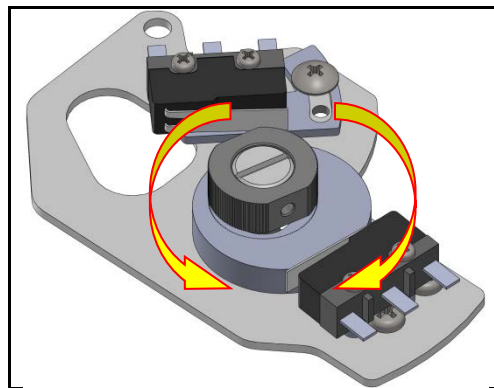
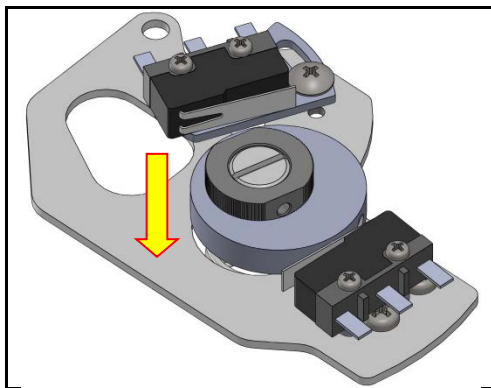

a) Push the red cam down and move.

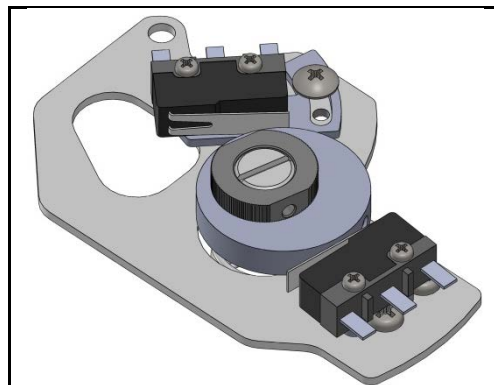
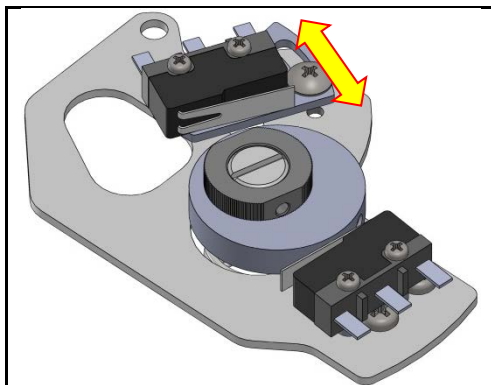

b) Turn the red cam until it touches the limit switch. And push up.

c) Do the same procedure with the blue cam. But push the blue cam up to move.

- Upper switch 1 terminals : 11, 12, 13

- Lower switch 2 terminals : 14, 15, 16

10. Quick Auto-Calibration

10.1. Quick Auto-Calibration

Supply 4-20mA input signal and push the MODE button for 5 seconds, the auto-calibration process will start.

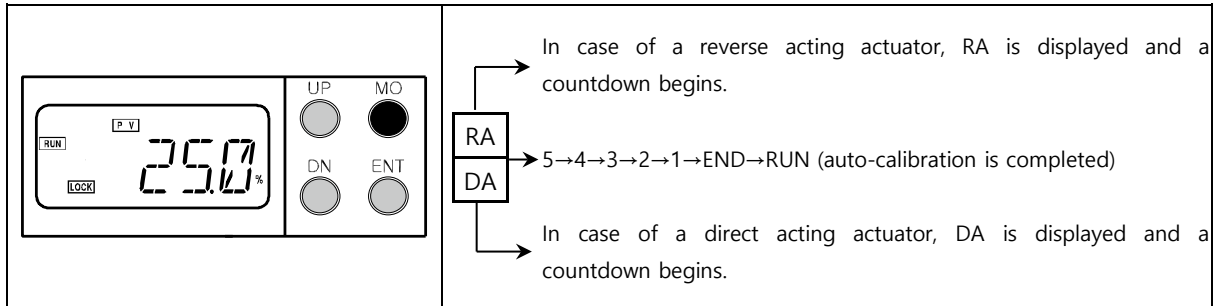

- ① It may take a longer time according to sizes of the control valve and the actuator. Generally, it will take 2 – 3 minutes with the standard size valve and actuator.
- ② If "MONT" is shown with the linear type SS2L positioner during an auto-calibration process, please make sure that the feedback lever is positioned horizontally at 50% open or close (See 11.4.6). Otherwise, please mount the SS2L positioner again.

- In case of the linear type SS2L positioner, "VALP / POSP" is shown as below. Please choose either VALP or POSP within 6 seconds by pushing the UP/DN button. Otherwise, "VALP" is set as standard.

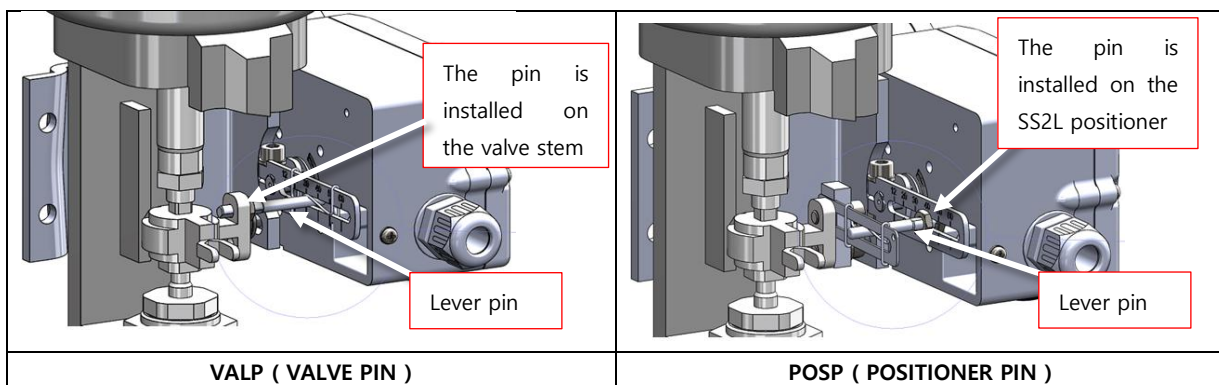

Note that if there is a difference between a selection of "VALP" or "POSP" and an actual installation of pin, it may cause a poor linearity.

10.2. Checking the Ambient Temperature

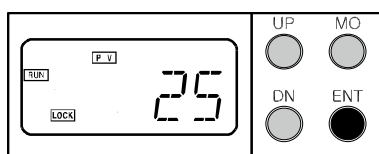

Keep pushing ENTER button, an ambient temperature surrounding the positioned will appear. Note that this ambient temperature appears only while pushing ENTER button.

11. Description of Parameters Flow

11.1. Diagram of Parameters

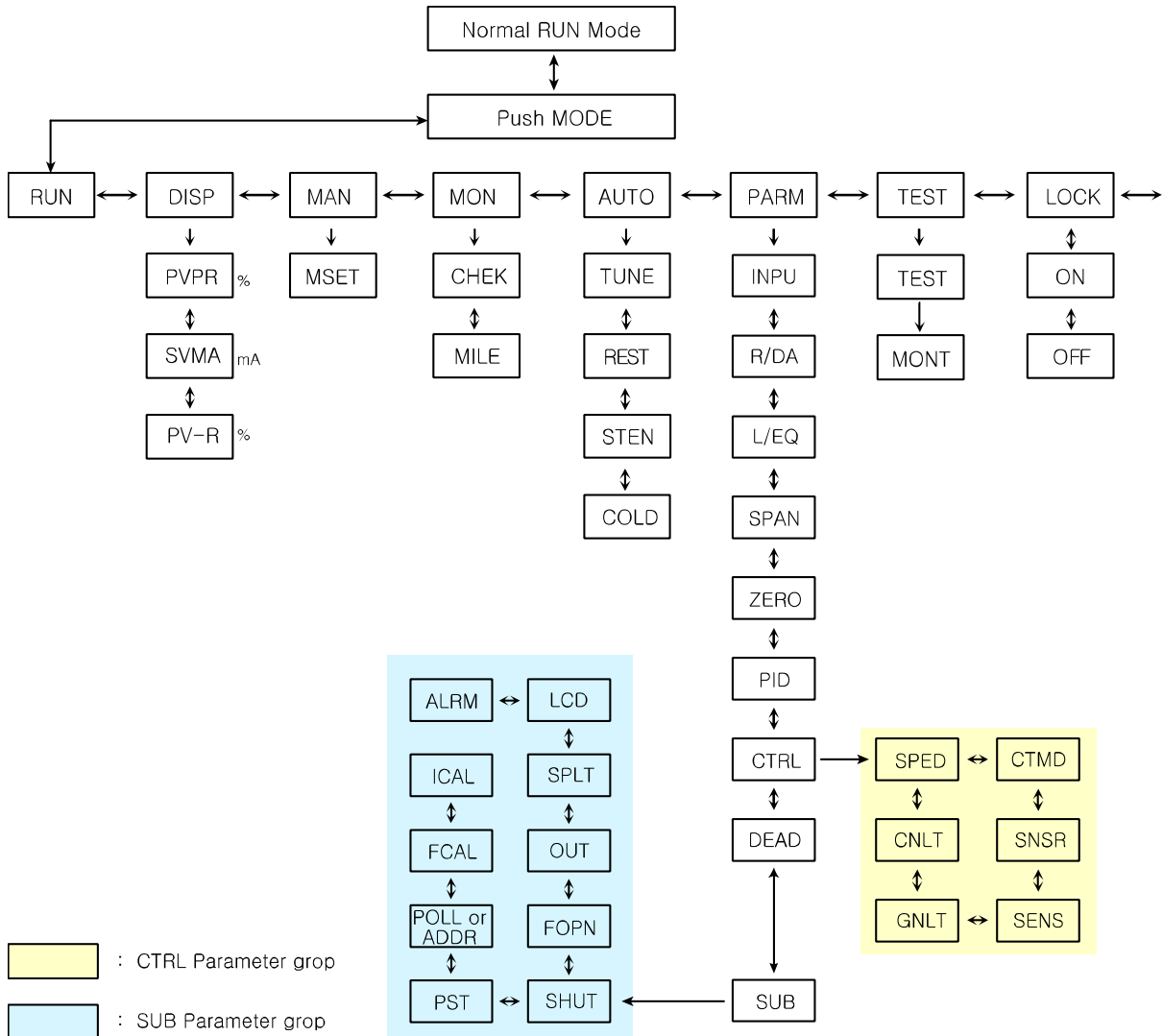

Note that the PST function (Partial Stroke Testing) is loaded at the factory on demand only when requested.

11.2. Main Parameters

Ref.	Parameter	Description	Function
11.4.2	DISP	DISPLAY	changes the LCD display mode
	PVPR	PV % value	shows the current position by %
	SVMA	Input signal mA value	shows the input signal by mA
	PV-R	PV % value (reversed value)	shows the current position by % in a reverse way (Ex. PVPR – 10% → PV-R – 90%)

Ref.	Parameter	Description	Function
11.4.3	MAN	MANUAL	operates the valve manually
	MSET	MANUAL-SET	operates the valve manually

Ref.	Parameter	Description	Function
11.4.4	MON	MONITOR	checks the current status of the positioner
	CHEK	ERROR CHEK	checks the errors occurred to the positioner
	MILE	Runtime	checks the total valve runtime

Ref.	Parameter	Description	Function
11.4.5	AUTO	AUTO-SET	performs auto-calibration and return to the factory settings
	TUNE	Auto-calibration	performs auto-calibration
	REST	RESET	returns to the factory settings
	STEN	START - END	re-sets the position of Zero and Span
	COLD	COLD START	re-boots the positioner

Ref.	Parameter	Description	Function
11.4.6	PARM	Sub-parameters	Please see the parameters on next page

Ref.	Parameter	Description	Function
11.4.7	TEST	TEST MODE	tests the positioner
	MONT	Checking of mounting status	confirms the mounting status of the positioner

11.3. Parameters

11.3.1. Main Parameters

Ref.	Parameter	Description	Function	Default
11.5.1	INPU	Input signal	4...20mA or 20...4mA	4...20mA
11.5.2	R / DA	RA / DA	Reverse acting or direct acting	RA
11.5.3	L / E.Q	Characteristic	Linear, E.Q. % (1:25 or 1:50), Quick open or User set (17points)	Linear
11.5.4	SPAN	Span adjustment	0...100%	100%
11.5.5	ZERO	Zero adjustment	0...99%	0%
11.5.6	PID	P-GN / I-GN / D-GN		Auto-set
11.5.7	CTRL	Control parameters	See 11.3.2 CTRL	•
11.5.8	DEAD	Signal dead band	0...9.99%	0%
11.5.11	SUB	Sub-Parameters	See 11.3.3 SUB	•

11.3.2. CTRL - Parameters (speed control adjustment)

Ref.	Parameter	Description	Function	Default
11.5.7.A	SPED	Response speed	0...1000	1000
11.5.7.B	GAP	CONTROL GAP		AUTO
11.5.7.C	KISP			AUTO
11.5.7.D	GHLT	GAP LIMIT		AUTO
11.5.7.E	CNLT	CONTROL LIMIT		AUTO
11.5.7.F	CTMD	High friction mode		NORM

11.3.3. SUB - Parameter

Ref.	Parameter	Description	Function	Default
11.5.9.A	SHUT	Shut-off	0...9.9%	0.3%
11.5.9.B	FOPN	Full-open	0...9.9%	0.3%
11.5.9.C	OUT	Output signal	4...20mA or 20...4mA	4...20mA
11.5.9.D	SPLT	Split range	4...12mA or 12...20mA	4...20mA
11.5.9.E	LCD	Change of display position	FOR / REV	FOR
11.5.9.F	ALAM	Alarm limit low, high	AL1L / AL1H, AL2L / AL2H	0...10%, 90...105%
11.5.9.G	ICAL	IN4M / IN20	sets the values in accordance with 4~20mA input signals	Factory setting
11.5.9.H	FCAL	FB4M / FB20	sets the values in accordance with 4~20mA output signals	Factory setting
11.5.9.I	POLL	HART polling address	0...15	0
11.5.9.J	PST	Partial stroke testing	checks a valve status	OFF
11.5.9.K	ADDR	PROFIBUS address	0...125	126



Note that the PST function (Partial Stroke Testing) is loaded at the factory on demand only when requested.

11.4. Setting of Main Parameters

The following abbreviations will be used hereafter.

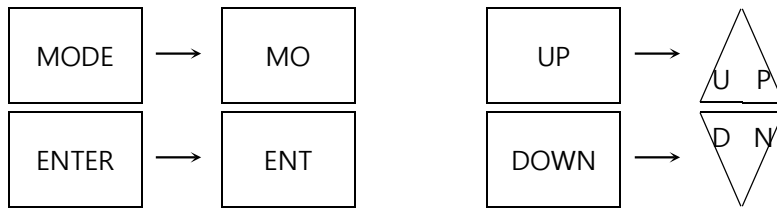

11.4.1. [LOCK] LOCK ON / OFF

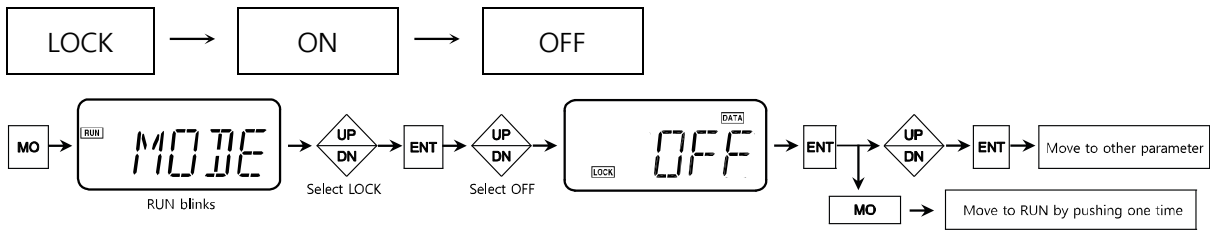

- ① LOCK ON : Saves all setting values.
- ② LOCK OFF : Be sure to LOCK OFF when it is necessary to read or change the selected parameters and the saved setting values.
- ③ Quick auto-calibration, Span, P-Gain can be carried out without LOCK Off (see "10. Quick Auto-calibration")

11.4.2. [DISP] Display Mode

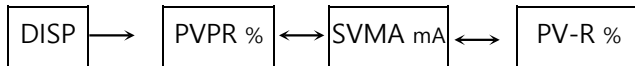

Selection of mA, % or in reverse way with values as shown

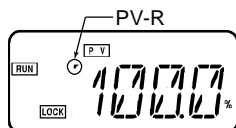
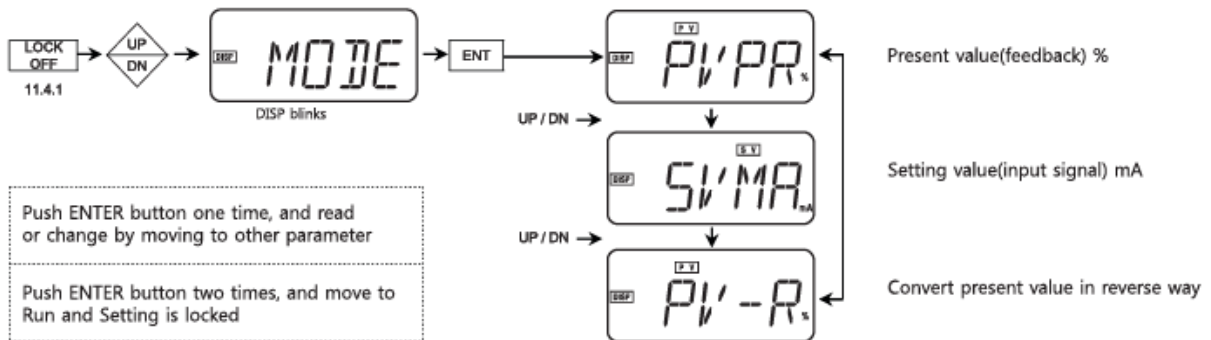

If PV-R is selected, the small point will blink as shown to the left.

Present value(PV) or setting value(SV) is displayed with mA or %. Setting value stands for input signal. If a control valve is a direct acting type and it is necessary to see the feedback values in a reverse way, select PV-R.

11.4.3. [MAN] Manual Mode (default: 0)

The valve can be moved to 0 – 100% manually.

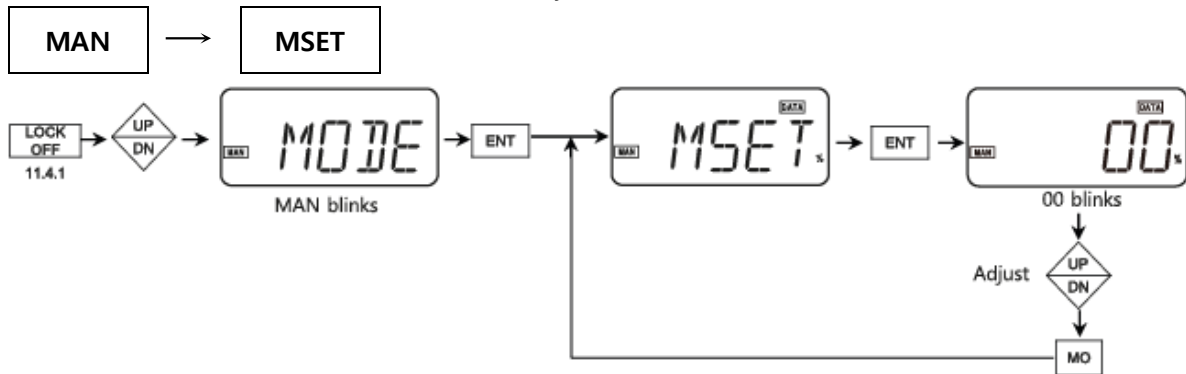

11.4.4. [MON] Monitor Mode

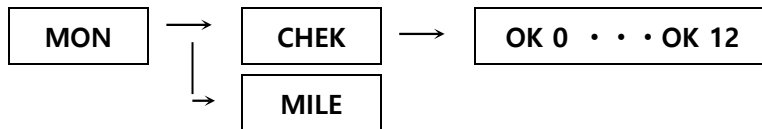

You can check the error codes and a total valve runtime.

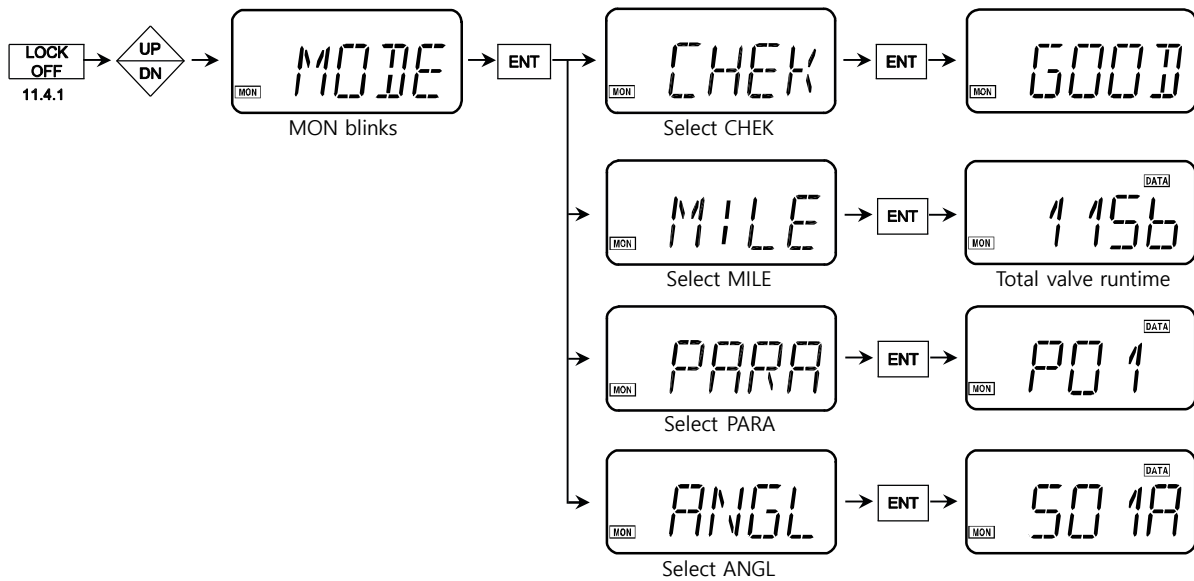

Number 1 in MILE corresponds to 10 hour. For example, if 1156 appears, it means that this valve has been working for 11,560 hours.

11.4.5. [AUTO] Auto-Calibration Mode



If necessary, initialize all setting values to the original values set after auto-calibration or return them to the factory setting values.

11.4.5.A [TUNE] Performing Auto-Calibration

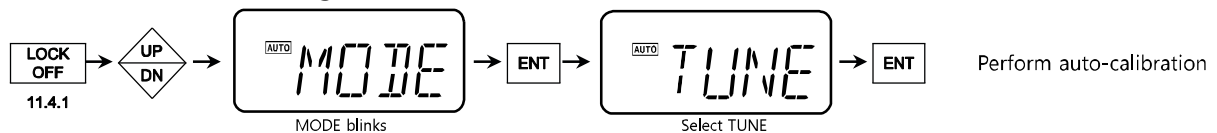

- ① Reverse acting (RA) is a standard factory setting. Even if air lines are connected wrongly by mistake, the SS2 positioner detects automatically and performs auto-calibration for direct acting (DA).
- ② If the actuator doesn't work with 4-20mA input signal properly, change air lines of OUT1 and OUT2 with each other and perform auto-calibration again.
- ③ For a reverse acting type (RA), a countdown will begin like RA-5-4-3-2-1-END. For a direct acting type (DA), a countdown will begin like 5-RA-DA-4-3-2-1-END.

11.4.5.B [RSET] Initializing Setting Values

All setting values return to the standard factory setting values.

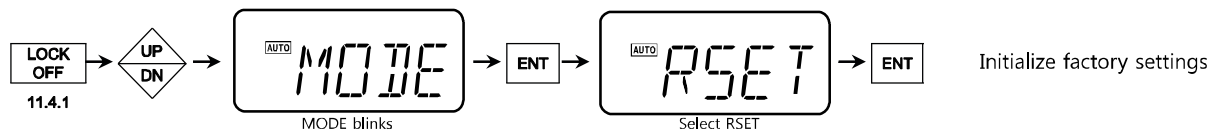

11.4.5.C [STEN] Re-adjustment of Zero & Span

Only Zero and Span is re-set without changing other values set after auto-calibration.

11.4.5.D [COLD] Re-booting

Restarts the program without changing any settings

11.4.6. [TEST] Self-Test Mode

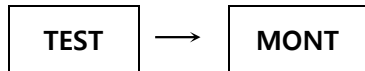

- The current valve mounting situation is shown. If the value is far away from 0, the valve will suffer from a poor linearity and hysteresis. Move the positioner and try to reach closer to 0 for the best linearity and hysteresis.

- How to set MONT

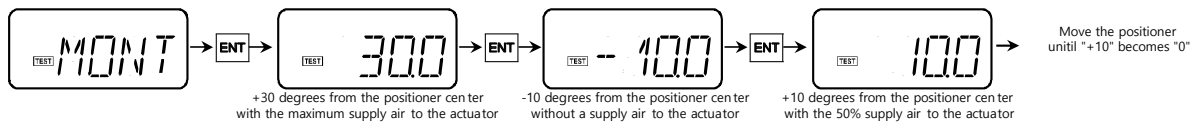

For information, on "MONT", the operating range (0~10kΩ) of the potentiometer is displayed.

- Step 1: Select MONT and push the ENT button one time, and the valve will be fully open or closed and also the actual valve position angle will be shown.
- Step 2: Push the ENT button one time, and the valve will be fully open or closed and also the actual valve position angle will be shown.
- Step 3: Push the ENT button one time, and the actual valve middle position angle will be shown. It shows the middle position angle between two ends (fully open and closed) measured through the above procedures of Step 1 and Step 2. Move the positioner upwards or downwards so that the valve position angle can reach closer to 0. And fix the mounting bracket tightly.

11.5. Parameters Flow Diagram

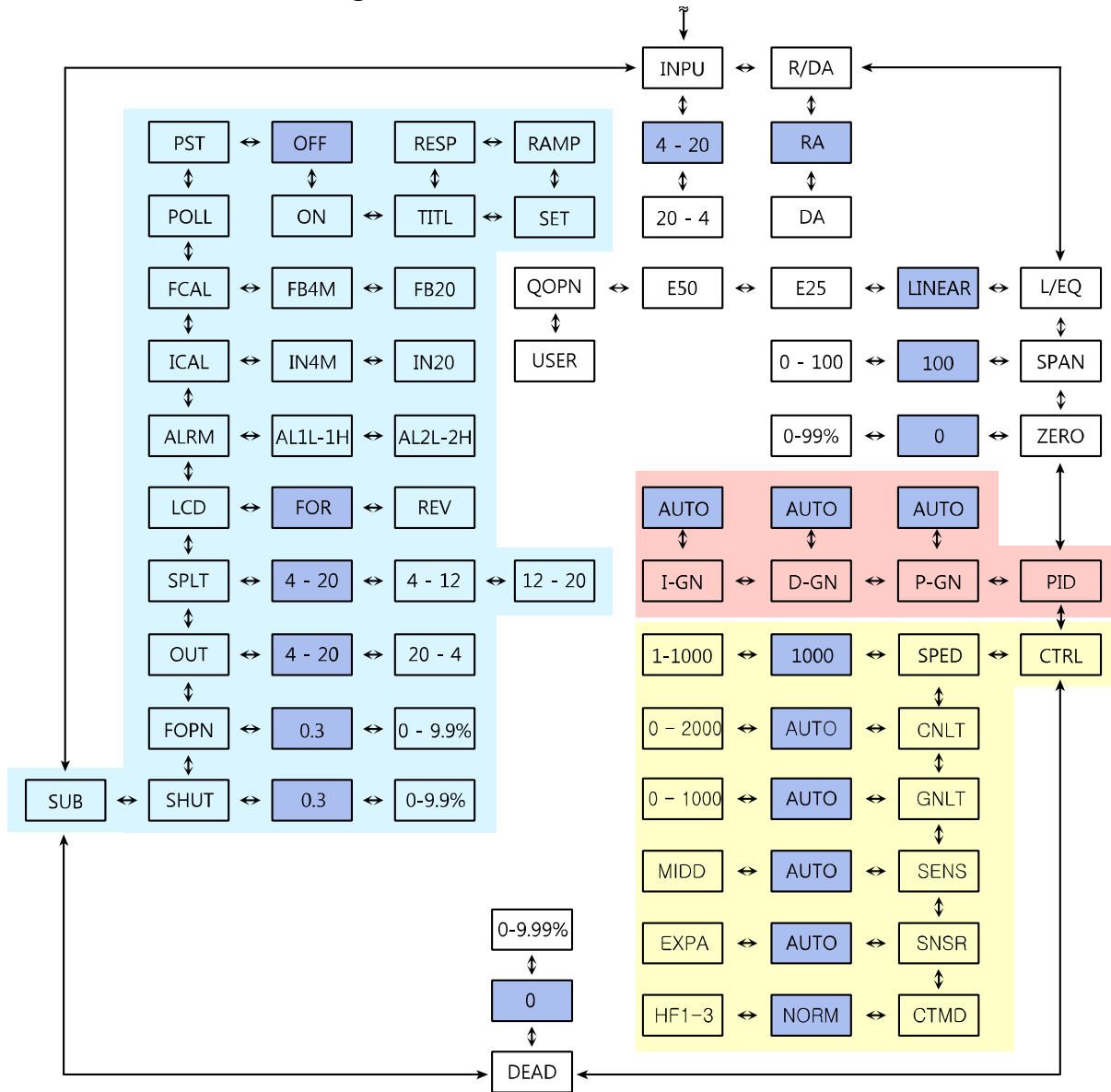

 The colored cells stand for the standard factory settings.
All setting values return to the standard factory settings if RESET begins.

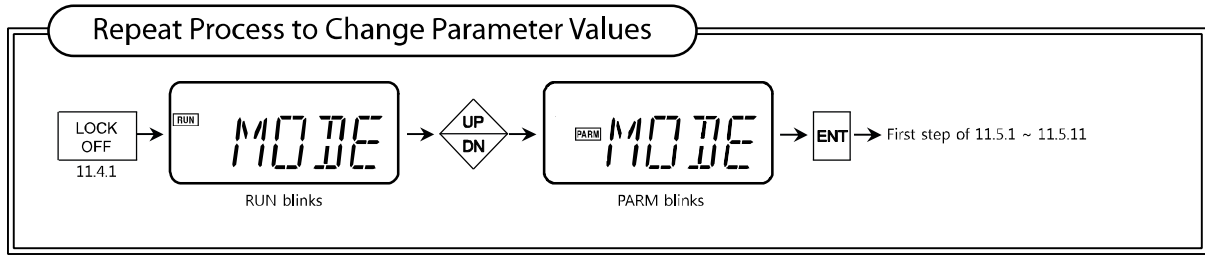

11.5.1. [INPU] Change of Input signal (default: 4-20mA)

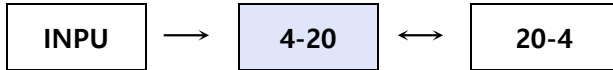

It is possible to make the positioner respond to 20-4mA input signals optionally even though 4-20mA input signals are supplied.

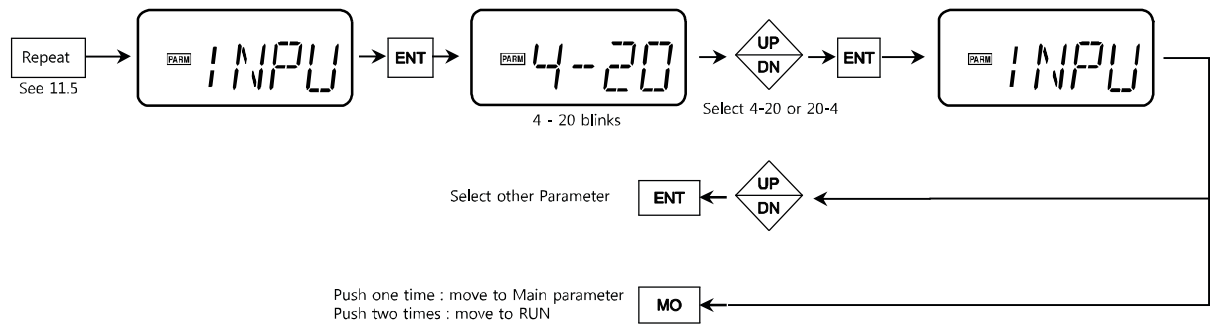

11.5.2. [R/DA] Selection of Direct Acting (DA) or Reverse Acting (RA) (default: RA)

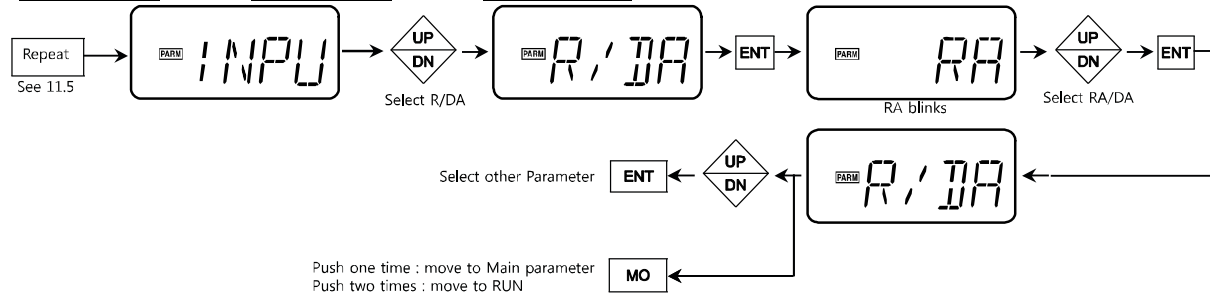
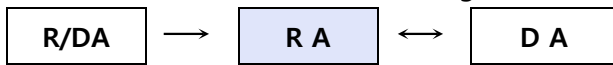

11.5.3. [L/EQ] Selection of Linear, E.Q.%, Quick Open or User Set (default: Linear)

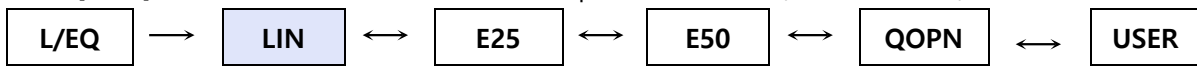

The valve characteristic can be changed to Linear, 1:25 EQ%, 1:50 EQ%, Quick Open or User Set.

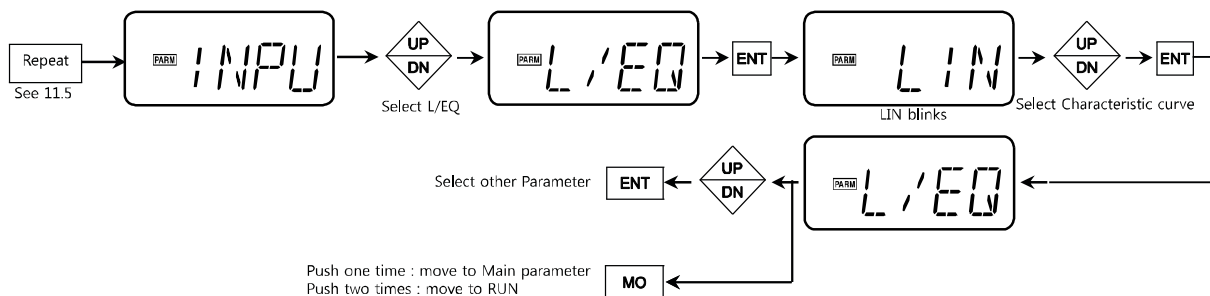

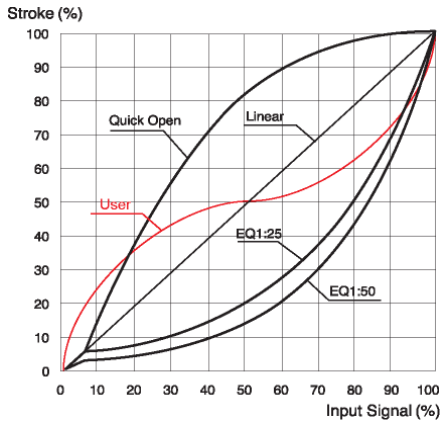

PARAM LIN	Linear
PARAM EQ25	EQ% (1 / 25)
PARAM EQ50	EQ% (1 / 50)
PARAM QOPN	Quick Open
PARAM USER	User set(17point)

- For the user setting,

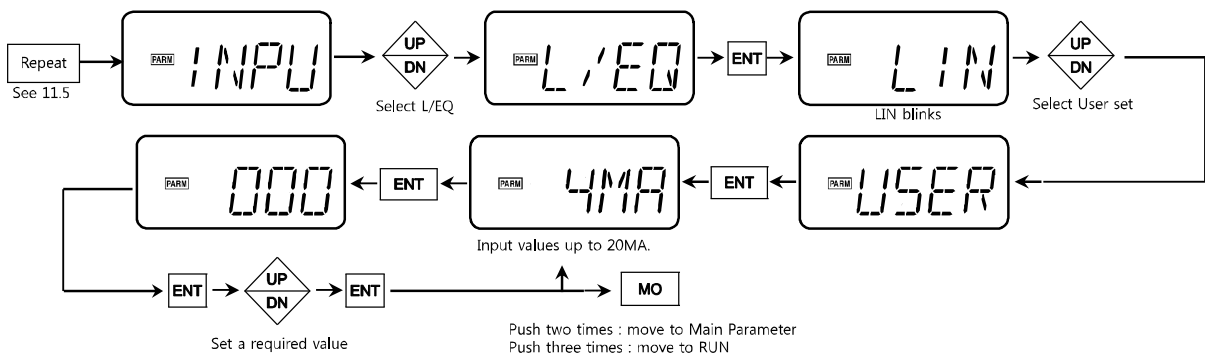

Example 1)

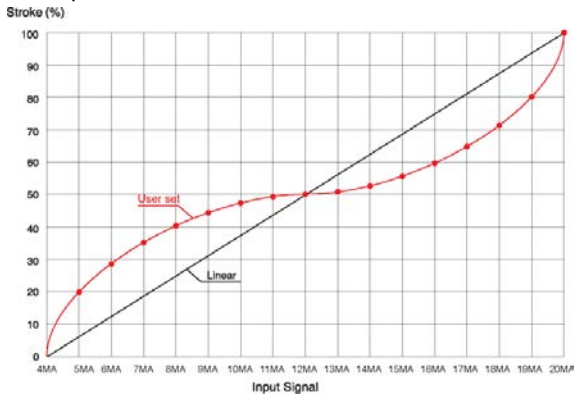

Point	Parameter	Input Signal (mA)	User Set Value	
			Ex-1	Ex-2
			Valve Opening% (set value)	
1	4MA	4mA	0	50
2	5MA	5mA	20	30
3	6MA	6mA	29	20
4	7MA	7mA	35	15
5	8MA	8mA	40	10
6	9MA	9mA	45	6
7	10MA	10mA	48	4
8	11MA	11mA	49	2
9	12MA	12mA	50	0
10	13MA	13mA	51	3
11	14MA	14mA	52	7
12	15MA	15mA	55	11
13	16MA	16mA	60	20
14	17MA	17mA	65	30
15	18MA	18mA	71	43
16	19MA	19mA	80	60
17	20MA	20mA	100	100

Example 2)

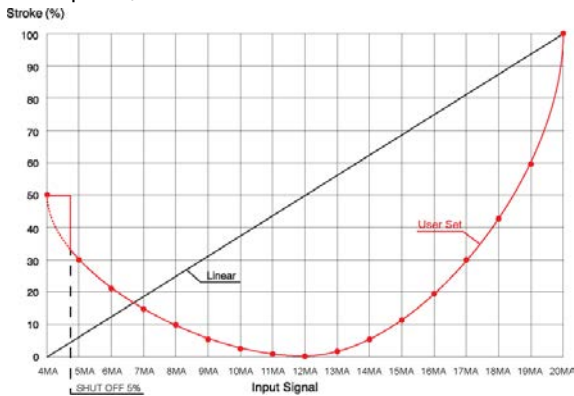

NOTES
1. This user setting has a linear characteristic as standard. 2. 5MA means % corresponding to 5mA. 3. Input all 4mA to 20mA for a required user set characteristic curve. ※ If Shut Off option is set, the set value at 4mA is maintained during interval of the Shut Off setting value as shown in Example 2). The curve goes according the user set value after interval of the Shut Off setting value. (0.3% is the default value of Shut Off.) As Shut-Off is set to 5% in Example 2), the curve maintains by 50% from 4 to 4.8mA and moves forward according to the user set.

11.5.4. [SPAN] Span Adjustment (default: 100)

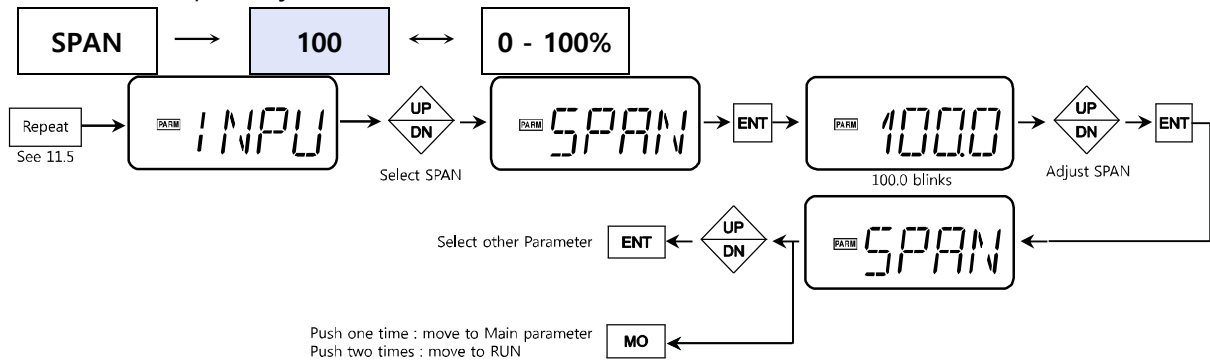

- ① Be sure to supply 20mA input signal before adjusting SPAN.
- ② Push ▼ DN button one time, Span will decrease by 0.1%. Keep pushing ▼ DN button, Span will decrease fast.
- ③ For a quick Span setting, push ▼ DN button for 5 seconds. (see 10.2)

11.5.5. [ZERO] Zero Adjustment (default: 0)

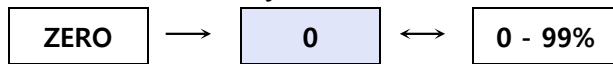

Zero can be adjusted to 0 – 99%.

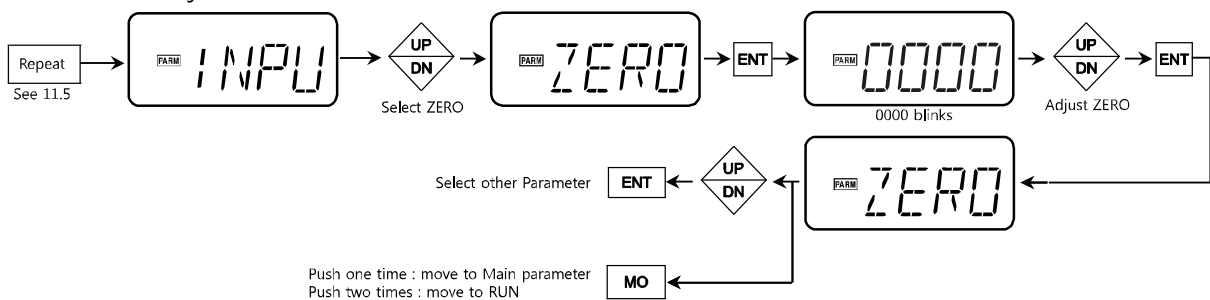

11.5.6. [PID] PID-Gain

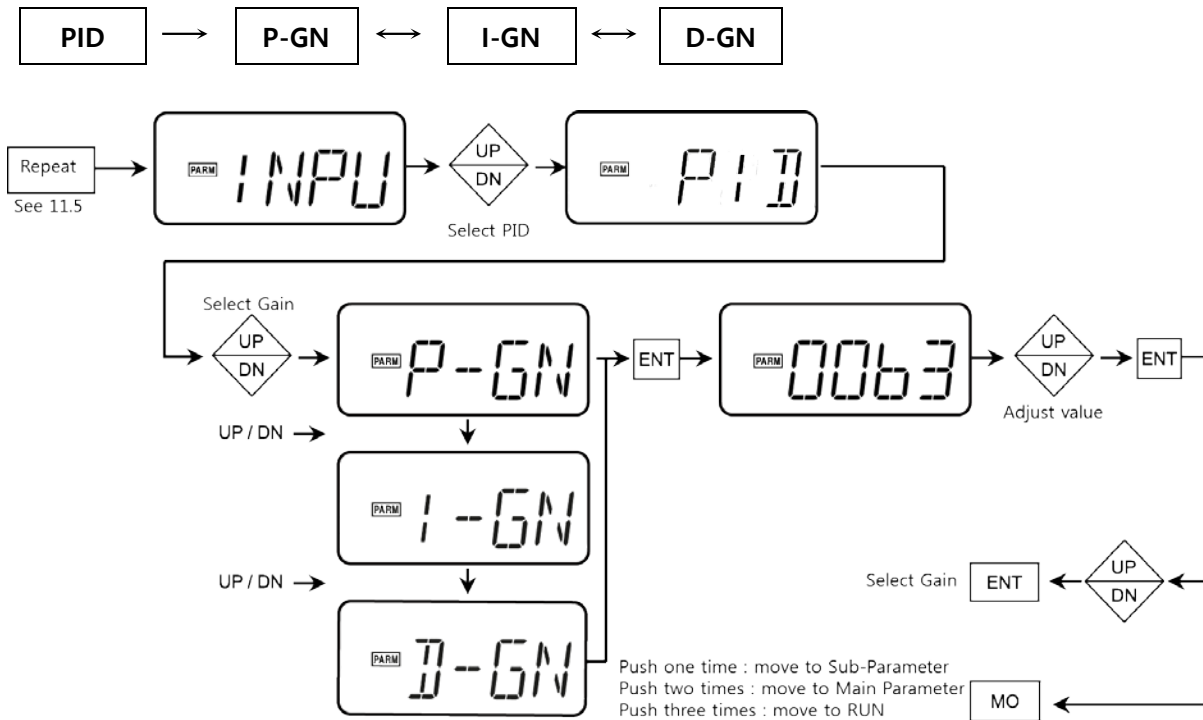

11.5.6.A [P-GN] P-Gain (Proportional Gain)

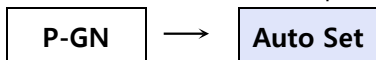

The micro-processor calculates P-Gain value during auto-calibration process in consideration of sizes of the valve and the actuator. If a hunting problem happens, decrease P-Gain value. If an oscillation problem happens, increase P-Gain value. P-Gain values are different according to the working conditions. In case of a small actuator, increase or decrease 5 to 10. In case of a big actuator, increase or decrease by 20 to 30.

11.5.6.B [I-GN] I-Gain (Integral Gain)

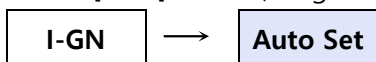

As I-Gain is set automatically during auto-calibration process, it is not necessary to change manually.

11.5.6.C [D-GN] D-Gain (Differential Gain)

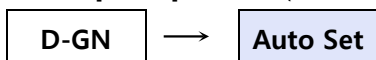

As D-Gain is set automatically during auto-calibration process, it is not necessary to change manually.

11.5.7. [CTRL] Control Speed Adjustment

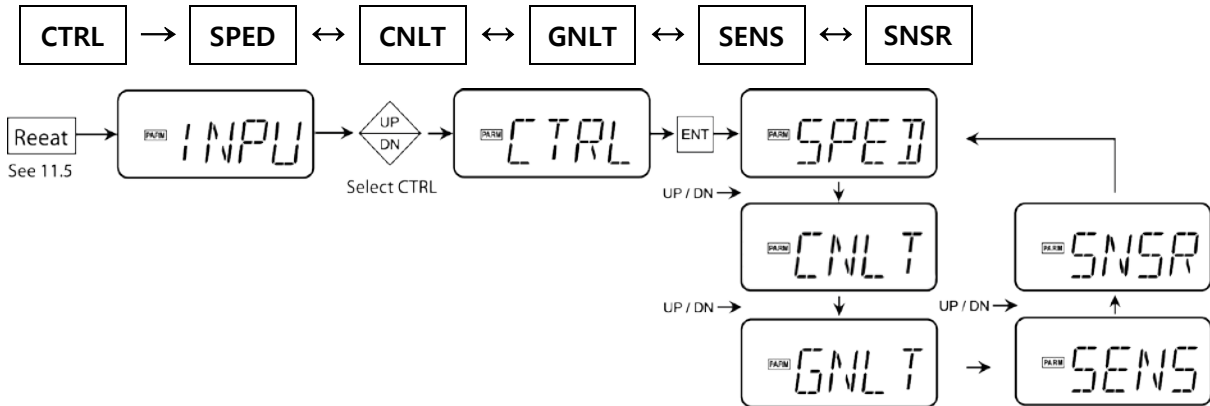

11.5.7.A [SPED] Response Speed Adjustment (default: 1000)

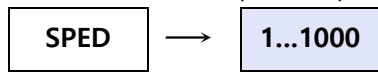

This is to adjust the response speed of the actuator. (Min: 1, Max: 1000)



11.5.7.B [CNLT] Control Limit (default: automatically-set)

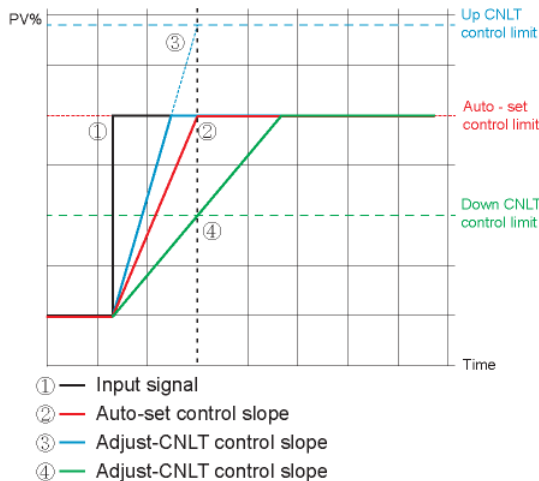
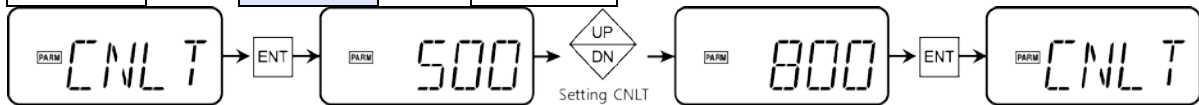
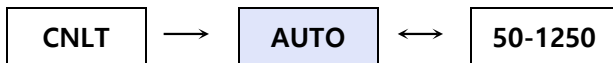

CNLT is to limit a control range and set automatically during an auto-calibration process. When 0% - 100% input signal is supplied, a recognition range of the positioner is settled according to CNLT.

If CNLT is increased as shown in Graph 3, a control speed can become faster but a hunting problem can happen. If CNLT is decreased as shown in Graph 4, a control speed can become slower but the positioner works more stably.

CNLT can be adjusted by 100.

11.5.7.C [GNLT] Gap Control Limit (default: automatically-set)

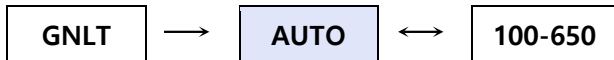

GNLT is to control a whole operating range. If the valve comes within $\pm 3\%$ of input signal, GNLT works with 1/2 value of CNLT for a safer control. In case that a hunting or oscillation problem happens around the position related to the input signal, a safer control can be accomplished by lowering GNLT.

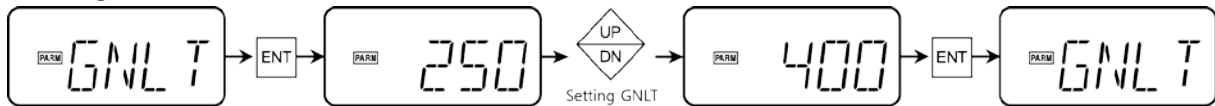

11.5.7.D [SENS] Setting of Sensitivity (default: MIDD)

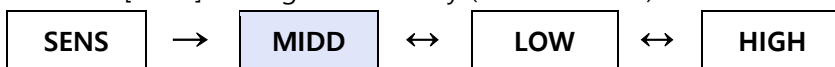

This is to set a sensitivity of positioner. For a more stable control, set to HIGH with a big actuator and to LOW with a small actuator.

11.5.7.E [SNSR] Setting of Sensor (default: EXPR)



This is to change the setting of linear type feedback lever connection to the valve.

	Default		In case that the feedback pin guide lever is connected to the positioner feedback lever
	No setting change		In case that the valve stem pin is connected to the positioner feedback lever

11.5.7.F [CTMD] Control Model for High Friction (default: NORM)

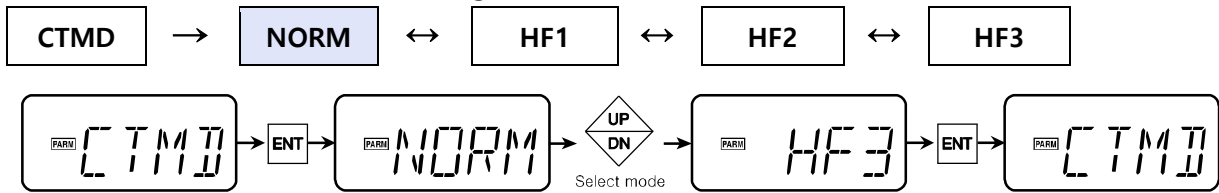

This is to get a more stable valve control in case that a hunting problem happens due to a high valve packing friction. There are 3 steps to select as below.

	Default		For hunting of 1 ~ 2%
	For hunting of 2 ~ 5%		For hunting of over 5%

11.5.8. [DEAD] Setting of Dead Band (default: 0.3)











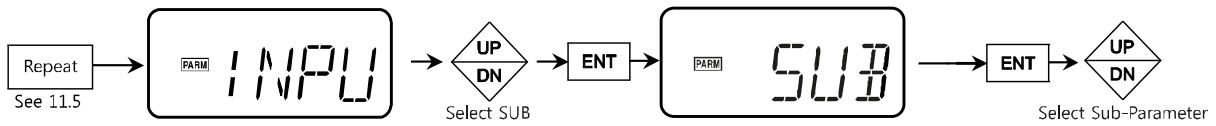

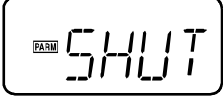
If there is a difference between Setting Value(SV) and Present Value(PV), adjust Dead Band to 0 - 9.99%.

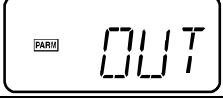

0.3% is a standard factory setting. For reference, 0.30 corresponds to 0.3% and the maximum value is 9.99 % (9.99).

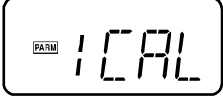
11.5.9. [SUB] SUB Parameter



Ref.	Parameter	Description	Function	Default
11.5.9.A		Shut-off	0...9.9%	0.3%
11.5.9.B		Full-open	0...9.9%	0.3%
11.5.9.C		Output signal	4...20mA or 20...4mA	4...20mA
11.5.9.D		Split range	4...12mA or 12...20mA	4...20mA
11.5.9.E		Change of display position on LCD	Forward or reverse direction	FOR
11.5.9.F		Alarm limit low, high	AL1L/AL1H, AL2L/AL2H	0...10%, 90...105%
11.5.9.G		IN4M / IN20	sets to values relating to 4-20mA input signal	Factory setting
11.5.9.H		FB4M / FB20	sets to values relating to 4-20mA output signal	Factory setting
11.5.9.I		HART polling address	0...15	0
11.5.9.J		Partial stroke testing	checks a valve status	OFF
11.5.9.K		PROFIBUS Address	Set PROFIBUS Address	126

11.5.9.A [SHUT] Valve Shut-off Control (default: 0.3)

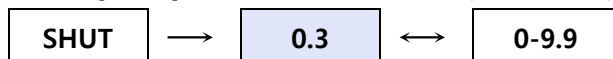

It is a safety function to close a valve completely. And it is possible to change 0% to 9.9%. For reference, 0.1% means that the positioner responds to 0.016mA. Therefore, the standard value of 0.3% means that a valve is closed at 4.048mA completely.



11.5.9.B [FOPN] Valve Full Open Control (default: 0.3)

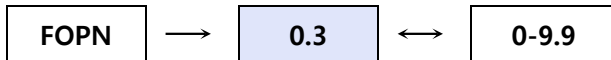

The valve can be fully open manually. And it is possible to change 0% to 9.9%. For reference, 0.1% means that the positioner responds to 0.016mA. Therefore, the standard value of 0.3% means that a valve is fully open at 19.952mA.



11.5.9.C [OUT] Setting of Output Signal (default: 4 - 20mA)

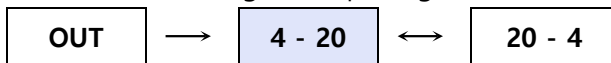

4 – 20mA is a standard factory setting. It's available to change to 20 – 4mA reversely.



11.5.9.D [SPLT] Split Range Setting (default: 4-20)

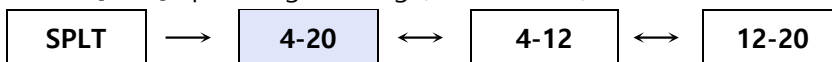

Split range can be set to 4-12mA or 12-20mA.



11.5.9.E [LCD] Change of Display Position on LCD

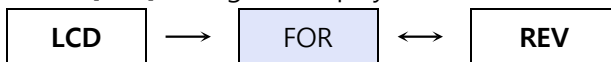

LCD is to change the display position on LCD in case that the positioner is installed upside down.

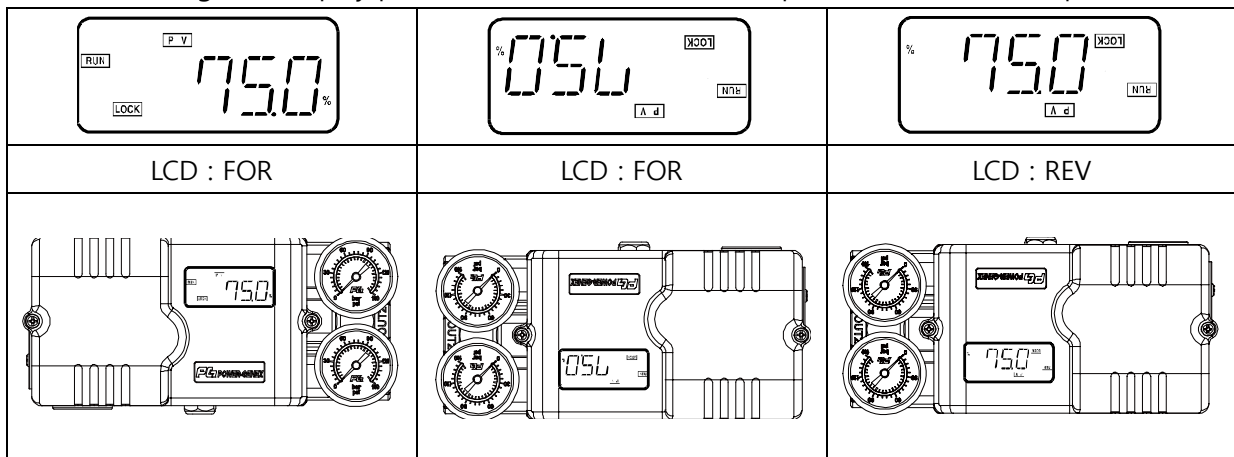

11.5.9.F [ALRM] Setting of Alarm Limits (default: 0 – 10%, 90 – 105%)

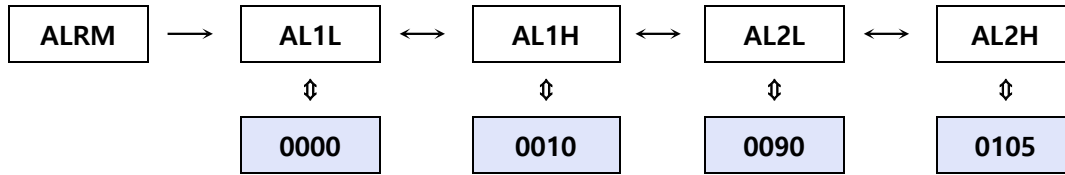

You can set an opening point or a closing point of a control valve. AL1 (L, H) is set to 0 – 10% and AL2 (L, H) is set to 90 – 105% from the factory as standard.

For example, see the below in order to re-set AL1 to 20 – 40% (AL1L = 20, AL1H = 40).

① AL1L Setting

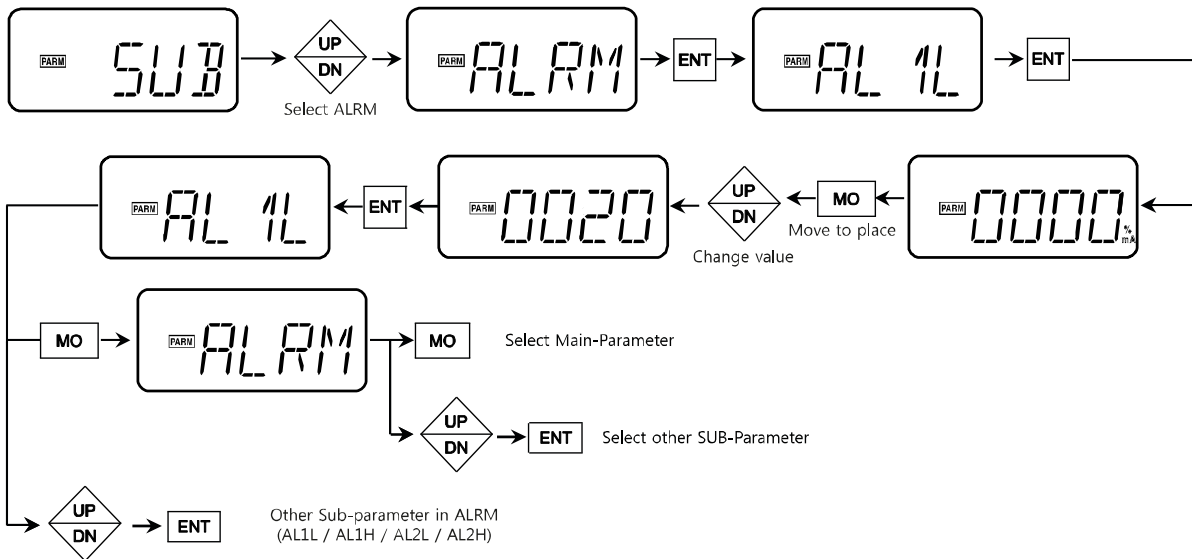

② AL1H Setting

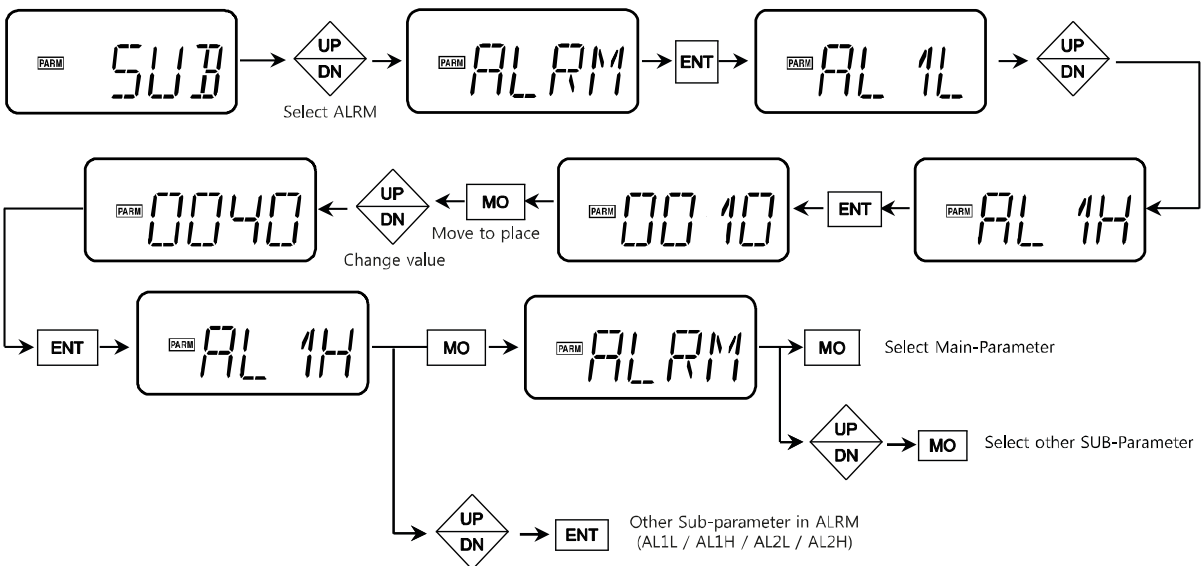

For example, see the below in order to re-set AL2 to 80 – 100%(AL2L = 80, AL2H = 100).

① AL2L Setting

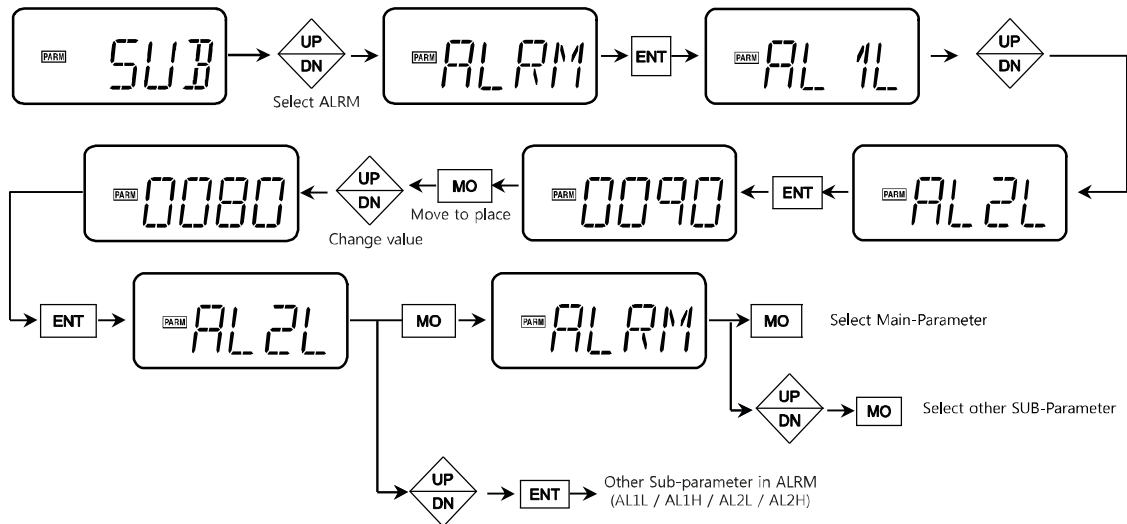

② AL2H Setting

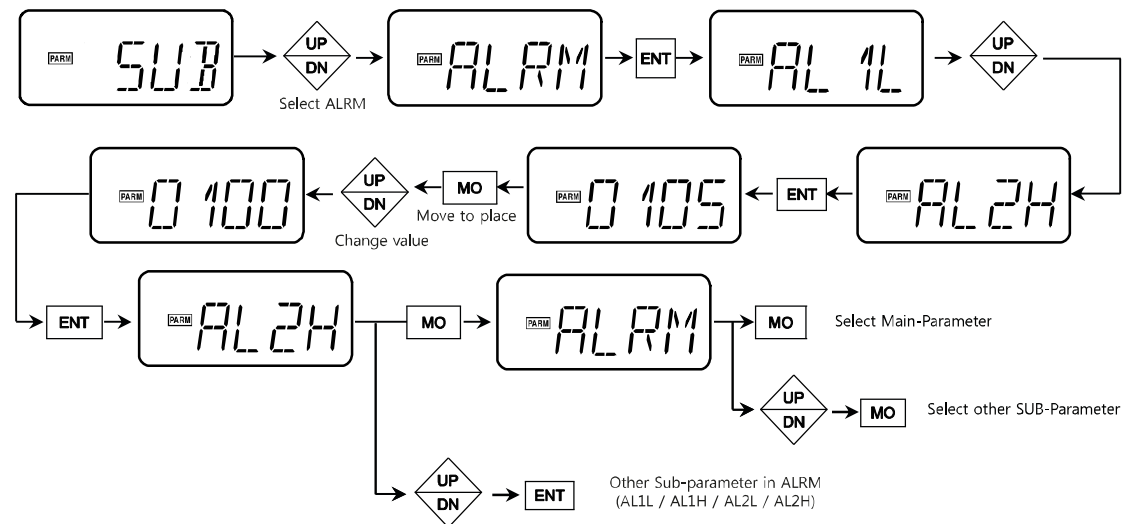

How to wire the Alarm Limits

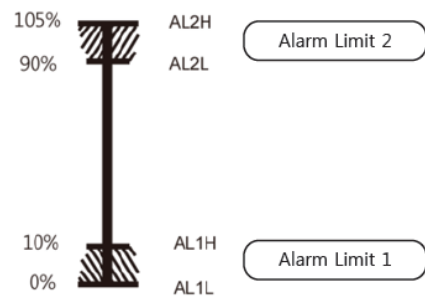
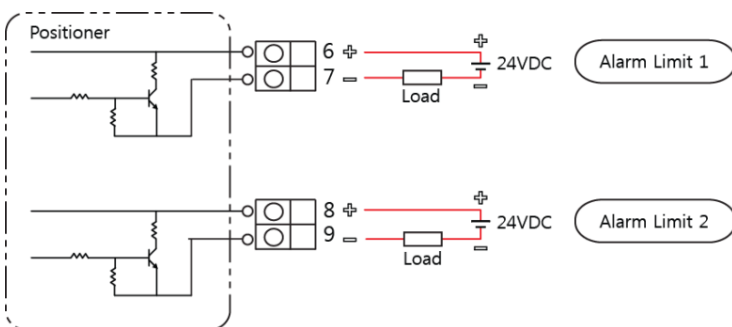

Alarm Limit Factory Setting



24VDC should be supplied for alarm limits.

11.5.9.G [ICAL] – Setting of Input Signal (default: factory setting)

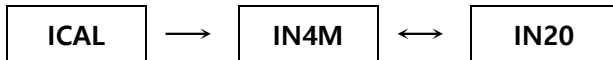

This is to match 4mA and 20mA input signals from a signal calibrator with the internal setting 0% and 100% of the positioner and save onto memory.

If 4mA output signal is measured as 4.2mA and 20mA output signal as 19.8mA with a signal calibrator on site, 4.2mA can be recognized as 0% and 19.8mA as 100% by re-setting with ICAL.

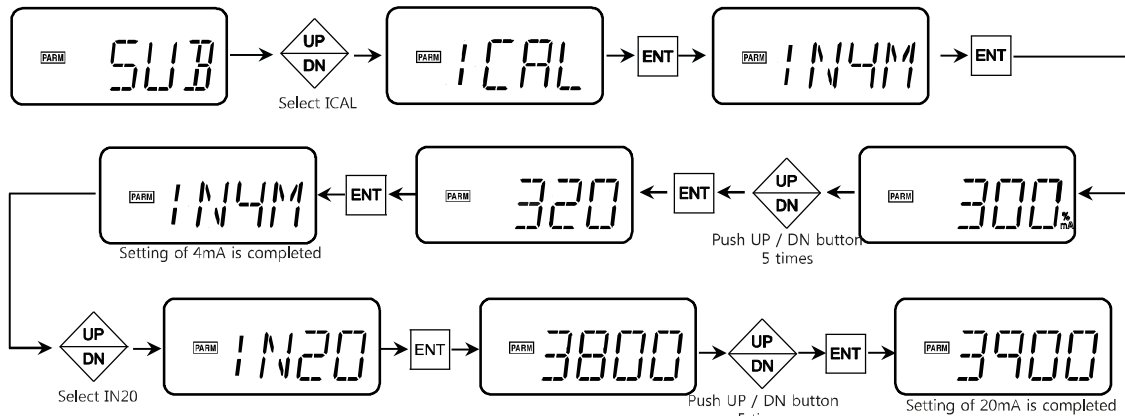

If ICAL is set at 4mA and 20mA, the middle output signals between 4mA and 20mA are set automatically. See [11.5.3 L/EQ] if it is necessary to change other characteristic curve.

11.5.9.H [FCAL] – Setting of Output Signal (default: factory setting)



This is to re-set the 4 – 20mA output signals coming from the positioner.

The factory setting is that 4mA is sent at 0% and 20mA is sent at 100%.

<Setting of FB4M>

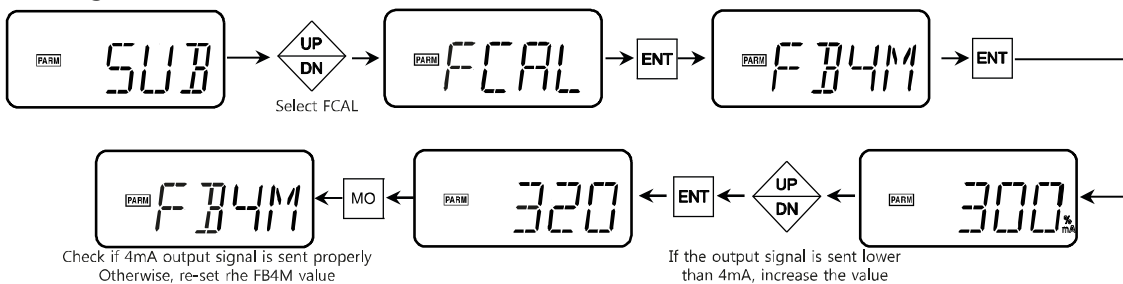

<Setting of FB20>

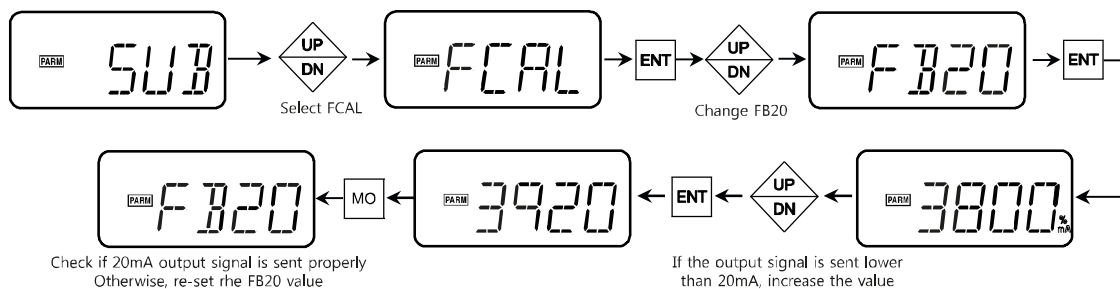

11.5.9.I [POLL] – HART Communication Polling Address (default: 0)

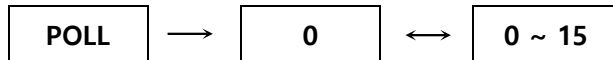

This is to select one of HART communication polling address (0 ~ 15) on site. The default address is "0".



As an unexpected problem can happens during communication, try to select after disconnecting HART communication.

11.5.9.J [PST] – Partial Stroke Testing (default: OFF)



Note that the PST function (Partial Stroke Testing) is loaded at the factory on demand only when requested.

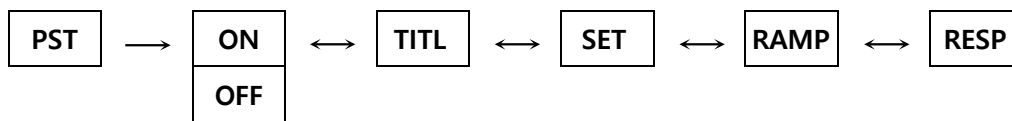

This is to move the valve periodically regardless of input signals and check the valve status.

	<ul style="list-style-type: none"> - to set the TEST time interval (default: '0024' – 24 hours) - Setting of '0000' shows the PST working status every 1 minute.
	<ul style="list-style-type: none"> - to set the moving point by % during TEST (default: 10%) - Valve position > 50% : move to the decreasing direction - Valve position < 50% : move to the increasing direction
	<ul style="list-style-type: none"> - to adjust a moving range per second (default: 1.0%/sec) - One of 1.0, 0.5, 0.25, 0.12, or 0.06%/sec can be selected.
	<ul style="list-style-type: none"> - to adjust a waiting time that the valve follows after the test signal (default: '10' seconds)
<p>Even though 'Good' is shown, if RESP is set too long, the judgment point will not be good for the next comparison. Also, if 'Bad' is shown, RESP is set too low. Adjust RESP.</p>	
	to show that there is no problem if the valve reaches Dead zone of the set position.
	to show that it is necessary to check the valve status if the valve fails to reach Dead zone of the set position.

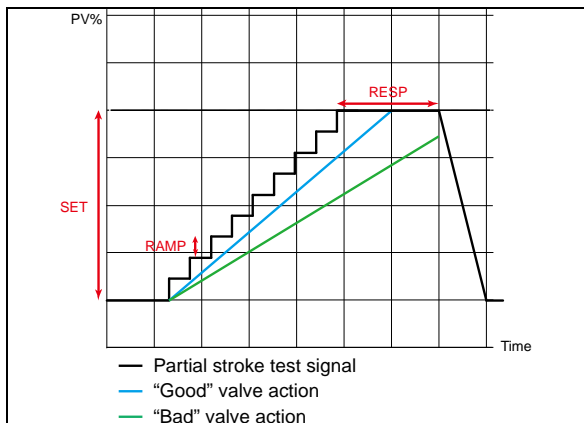

- It is possible to prevent the valve from getting stuck in the long term.
- Do not activate the PST function if it is not intended to use.
- The PST function is deactivated after auto-calibration.

11.5.9.K [ADDR] - PROFIBUS Communication Address (default: 126)

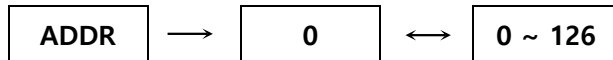

This is to select one of PROFIBUS communication address (0 ~ 125) on site. The default address is "126".

12. Maintenance / Service

12.1. Preliminary Check Points

12.1.1. Voltage

- The positioner commonly requires 4-20mA @ 24VDC for operation.
- Voltage drop (impedance): Without HART – 8.7VDC (435Ω @ 20mA)
With HART – 9.4VDC (470Ω @ 20mA)

12.1.2. Electrical Connections

Check polarities (+, -) of 4-20mA input signal definitely and make the electrical connections.

12.1.3. Pneumatic Connections (see 8.1, 8.2)

12.1.4. Supply Air Quality

A supply air should be definitely clean and compressed free of water, moisture or oil in conformance with IEC 770 and ISA-7.0.01.

12.2. Module Parts

- ① RTQ Coil Assembly (spare part No. 12)
- ② Pilot Valve Assembly (spare part No. 5)
- ③ PCB Control Board Assembly (spare part No. 3)

12.3. Re-setting of Potentiometer (spare part No. 14a, 14b)

It is necessary to adjust a setting of potentiometer as below when a gear position is moved due to user's carelessness. For reference, 0~10kΩ potentiometer is installed into the SS2 positioner.

- ① Dis-install the electronic card from the SS3 positioner and make the markings on two gears match with each other.
- ② Move the feedback lever to 50% position and adjust a potentiometer so that it can reach nearly 5kΩ.
- ③ Re-install the SS3 positioner onto the valve and re-perform auto-calibration.

12.4 Exchanging the Positioner Spare Parts



- ① Begin procedure after complete removal of supply air.
- ② Re-start auto-calibration procedure after exchanging spare parts

12.4.1 How to Exchange SS3L / SS3R Pilot Valve

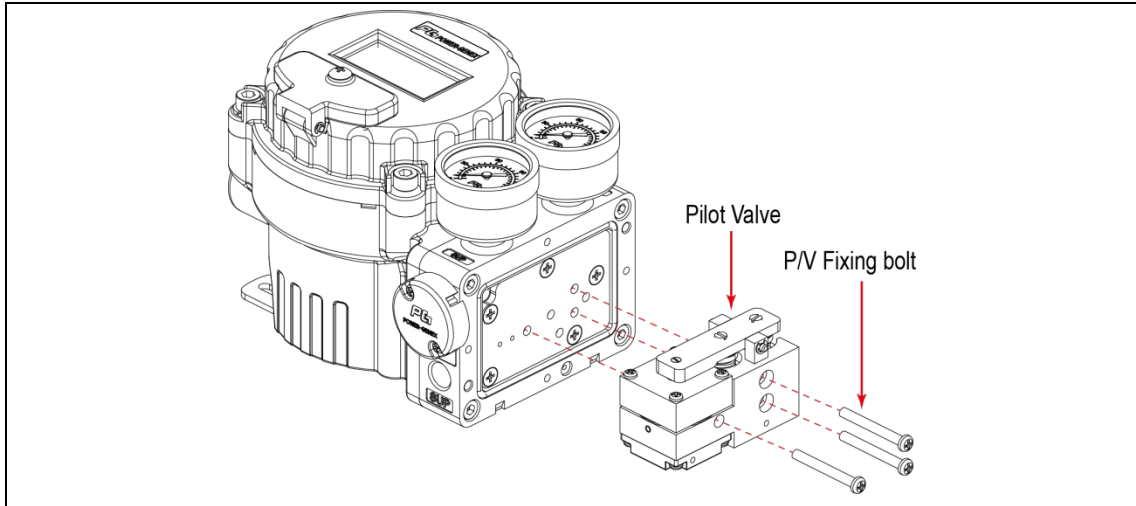

- ① Disassemble the Pilot valve cover.
- ② Disassemble the fixing bolts (3EA) after removing the pilot valve cover
- ③ Disassemble the pilot Valve
- ④ Re-assemble using the new pilot valve by following above steps reversely.
- ⑤ Re-start auto-calibration after completing assembly

12.4.2 How to Exchange SS3L / SS3R RTQ

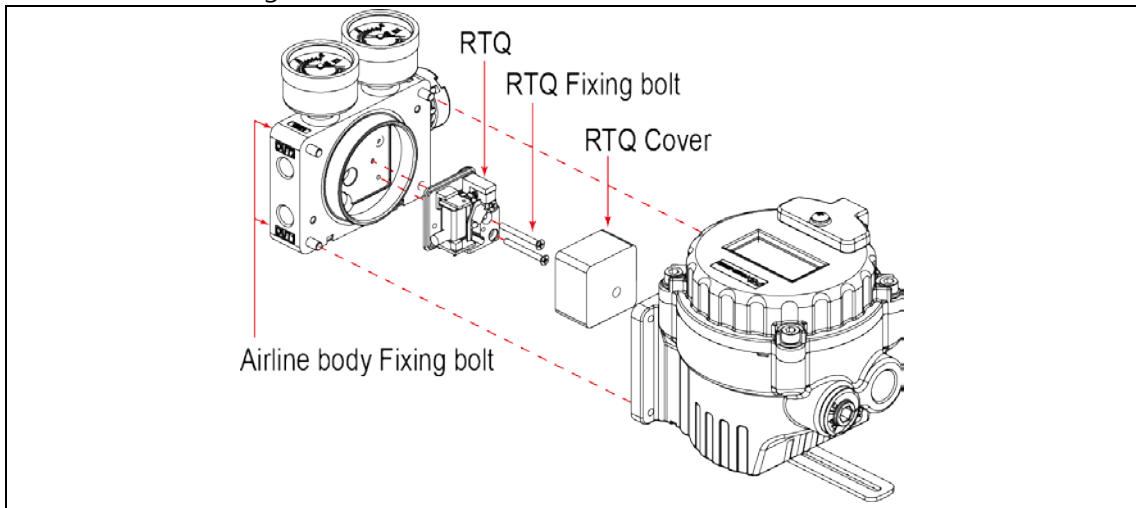

- ① Disassemble the pilot valve cover
- ② Disassemble the fixing bolts (4 pcs) fastened on airline body after removing the pilot valve cover
- ③ Detach airline body from the positioner body
- ④ Disassemble the bolt (1 pc) after removing the seal on RTQ cover bolts
- ⑤ Disassemble the fixing bolt (2 pcs) after removing the RTQ cover
- ⑥ Disassemble the RTQ
- ⑦ Re-assemble using new RTQ by following above steps reversely.
- ⑧ Re-start auto-calibration after completing assembly

13. Troubleshooting

13.1. Error Codes and Recommended Actions

If the positioner doesn't work properly and DATA on LCD blinks, try to take action as below.

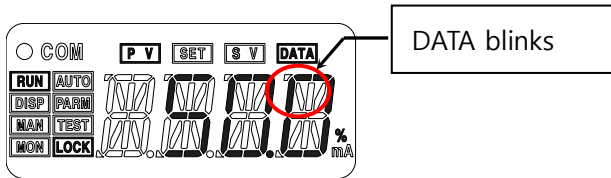

Error Code	Cause	Symptom	Action
CMLO	Low input current (3.7mA)	Data on LCD are shown too dim or too bright.	Re-check 4 – 20mA input signals.
CMHI	High input current (20.5mA)		
IGMI	Down Speed Long	Slow operation	The actuator is too big. Use the air volume booster.
IGMX	Up Speed Long		
H/RX	HART Rx Error	HART signal failure	Re-set and re-connect will be done after 2.5 seconds, but it is necessary to check the communication system in case of a continuous error.
MONT	Operating angle out of range	MONT is shown during step 4 and an auto-calibration process is finished without completion.	Re-install the SS2L / SS2R positioner.
LOTT	Bias Low	The valve is not closed or moves slowly.	Loosen a valve packing.
HITT	Bias High	The valve is not open or moves slowly.	
FBFT	Feedback error (0 - 1%)	PM00 is shown at step 4 and an auto-calibration is finished without completion.	Defectiveness of potentiometer socket contact or PCB board
FBSM	Feedback error (2 - 9%)	The operating stroke is too small and the valve doesn't work smoothly.	Re-install the potentiometer and increase the operating angle of the feedback lever.
BAD	PST error	BAD is shown.	Check the valve or increase the response time of PST.
PONT	Potentiometer Error	Problem of potentiometer	Check the potentiometer (Potentiometer Ass'y, Board)
RTQ	Coil Error	Problem of coil	Check the coil assembly.

14. Spare Parts

14.1. SS3 Parts

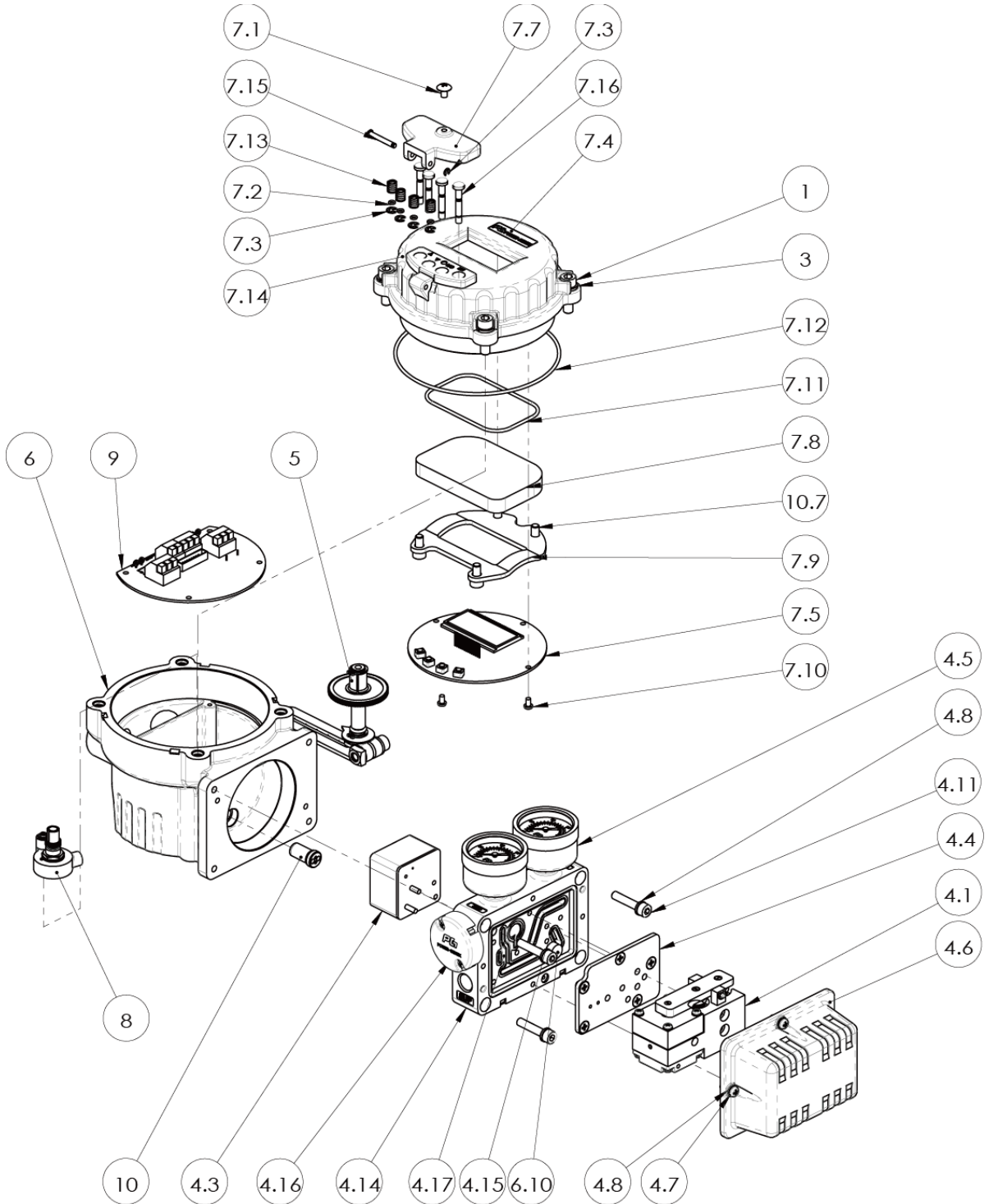

14.2. List of Spare Parts

No.	Part No.	Description
3	PG-SS3-01	Airline body ass'y
4.1	PG-SS3-02	SS3 pilot valve ass'y
4.3	PG-SS3-03	Coil ass'y
4.4	PG-SS3-04	Airline plate
4.5	PG-SS3-05	Gauge
4.6	PG-SS3-06	PV cover
6.10	PG-SS3-07	Flame arrest
4.14	PG-SS3-08	Airline body
4.16	PG-SS3-09	Vent Unit
4.17	PG-SS3-10	Airline Oring
5	PG-SS3-11	Shaft ass'y
6	PG-SS3-12	SS3 Main body
7	PG-SS3-13	SS3 Cover ass'y
7.4	PG-SS3-14	PG logo
7.5	PG-SS3-15	SS3 Main board
7.7	PG-SS3-16	Button cover
7.8	PG-SS3-17	Glass
7.9	PG-SS3-18	Glass fix plate
7.13	PG-SS3-19	SS3 button spring
7.14	PG-SS3-20	SS3 main cover
7.15	PG-SS3-21	Cover pin
7.16	PG-SS3-22	Button
8	PG-SS3-23	Potentiometer Ass'y
9	PG-SS3-24	Terminal board
10	PG-SS3-25	Wire thread

15. Dimensions

15.1. SS3L (linear type)

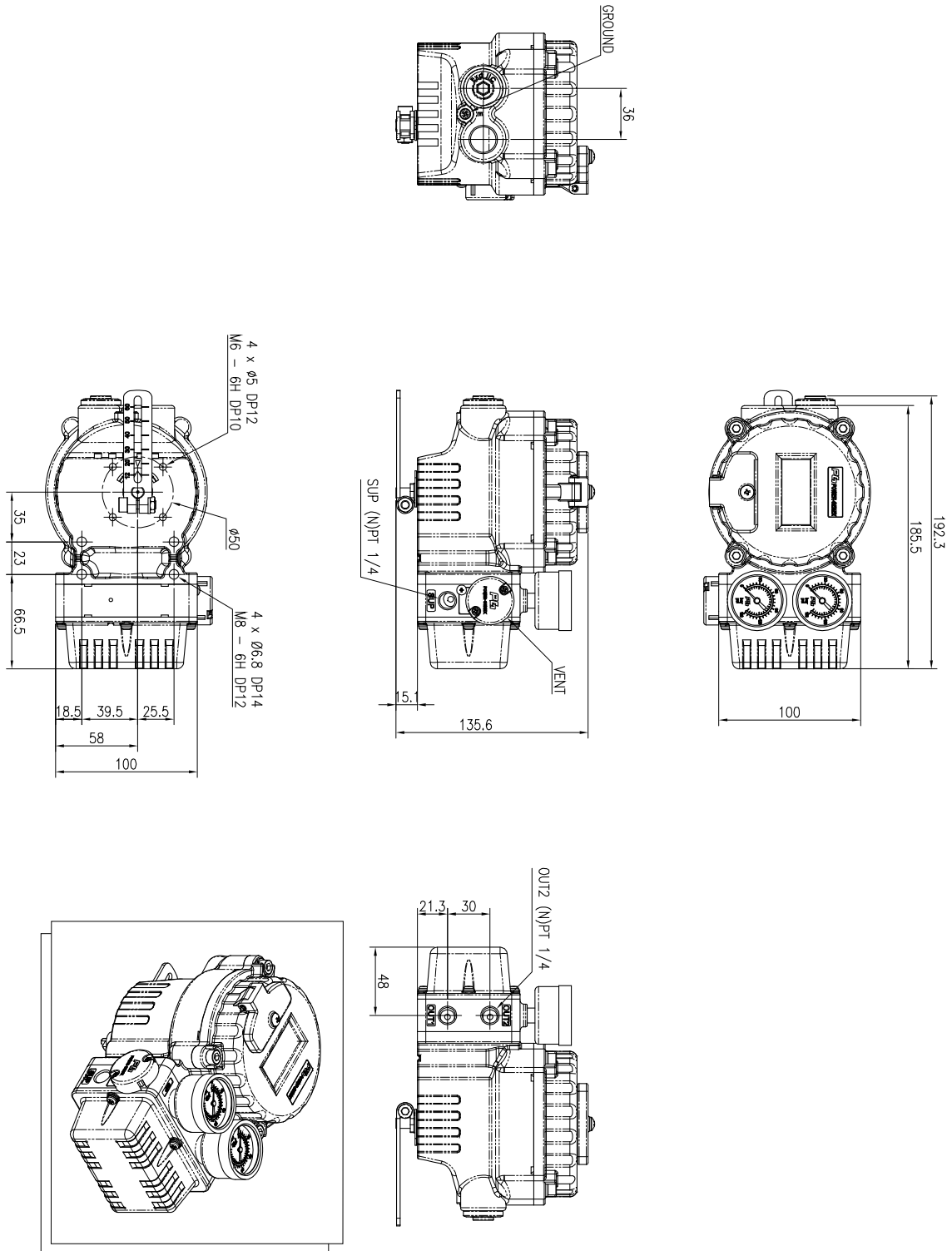

15.2. SS3R (rotary type)

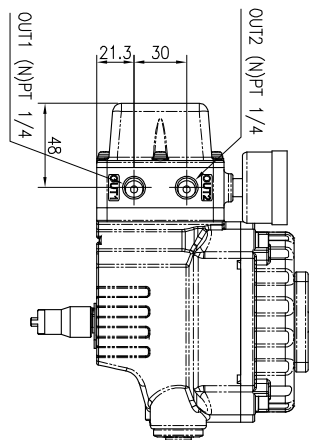
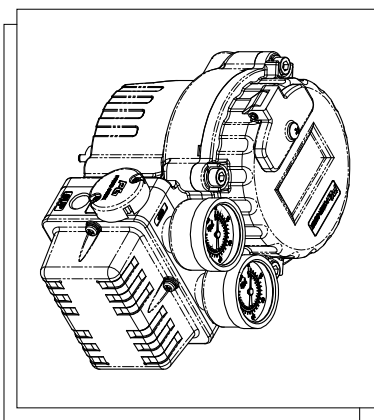
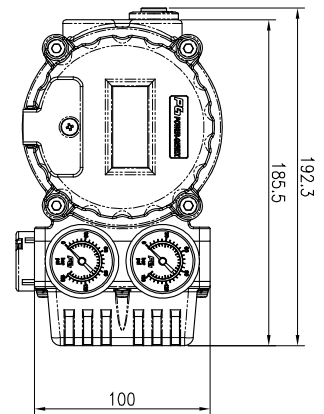
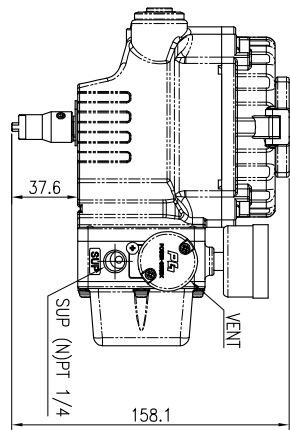
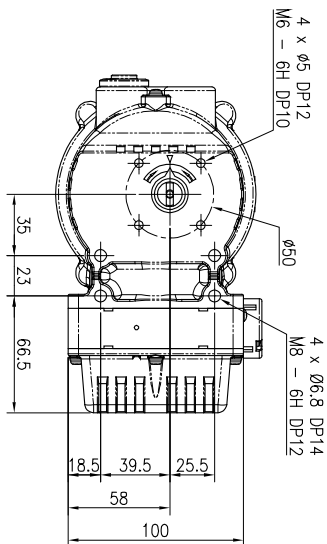
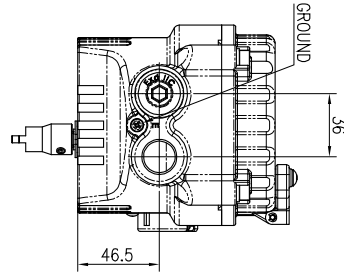
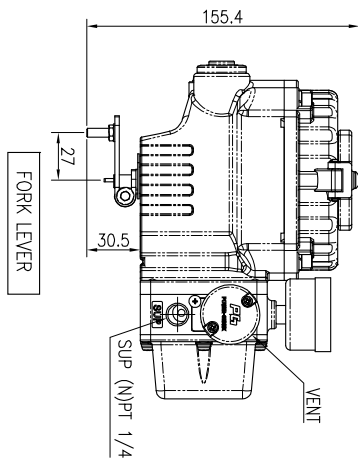

Warranty

1. The warranty period of the product is 1.5 years after the product is shipped from Power-Genex in Korea.
2. For any failure or damage reported within the warranty period which is clearly our responsibility, a replacement product or necessary parts will be provided. This limited warranty applies only to our product independently, and not to any other damage incurred due to the failure of the product.
3. If a problem happens with the following reasons, please note that the reasonable repairing costs will be charged even during a warranty period.
 - In case that customers retro-fit the products improperly without any instructions from Power-Genex
 - In case that the products are damaged by a bad delivery, storage or handling beyond design conditions
 - In case that the products are used beyond specifications
 - In case that the products are damaged by an improper installation
 - In case that the products are damaged by fire, earthquake, storm, flood, thunder, lighting, other natural disasters, riot, war, exposure to radioactivity
4. If maintenance is required, please contact distributors or Power-Genex directly. A proper and satisfactory customer service will be provided.



Power-Genex Ltd.

99, Eunbong-ro, Namdong-gu, Incheon 405-849 Korea

Tel : +82-32-812-6644

Fax : +82-32-812-6645

Website : <http://www.powergenex.com>

E-mail : sales@powergenex.com

Subject to change without prior notice