

2 WAY 3 PIECE STAINLESS STEEL SCREWED BALL VALVE

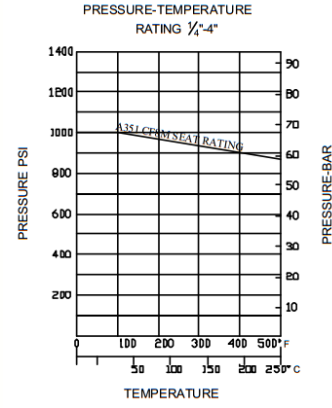
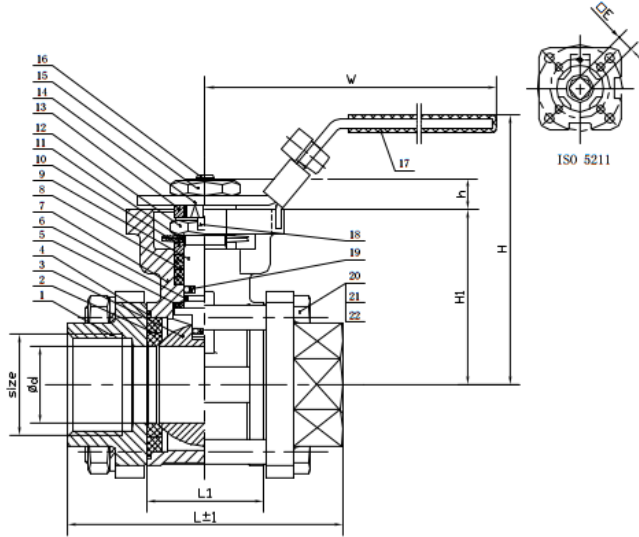

| SIZE | DN (mm) | L | L1 | Ød | H | H1 | h | W | □E | ISO 5211 |
|--------|---------|-----|-----|------|-------|-----|-----|-----|----|----------|
| 1/4" | 8 | 60 | 22 | 10.5 | 58 | 31 | 7.5 | 110 | 9 | F03/F04 |
| 3/8" | 10 | 60 | 22 | 12 | 58 | 31 | 7.5 | 110 | 9 | F03/F04 |
| 1/2" | 15 | 75 | 27 | 15 | 67 | 40 | 8 | 110 | 9 | F03/F04 |
| 3/4" | 20 | 80 | 33 | 20 | 73 | 46 | 8 | 110 | 9 | F03/F04 |
| 1" | 25 | 90 | 38 | 25 | 88 | 57 | 10 | 160 | 11 | F04/F05 |
| 1 1/4" | 32 | 110 | 50 | 32 | 95 | 64 | 10 | 160 | 11 | F04/F05 |
| 1 1/2" | 40 | 120 | 54 | 38 | 107.5 | 71 | 14 | 185 | 14 | F05/F07 |
| 2" | 50 | 140 | 68 | 50 | 118.5 | 82 | 14 | 185 | 14 | F05/F07 |
| 2 1/2" | 65 | 185 | 85 | 65 | 168 | 98 | 16 | 305 | 17 | F07/F10 |
| 3" | 80 | 205 | 99 | 78 | 178 | 110 | 16 | 305 | 17 | F07/F10 |
| 4" | 100 | 240 | 130 | 100 | 198 | 130 | 18 | 305 | 19 | F07/F10 |

| Main Technical Parameter | | | |
|--|---------------------|---------|-----|
| Normal pressure | | 6.3 | MPa |
| Test pressure | Shell test pressure | 9.5 | MPa |
| | Tightness test | 6.9 | |
| | Gas-Tightness test | 0.6 | |
| Max working temperature | | -20~160 | °C |
| Applicable medium: water, gas, oil, acid | | | |

TECHNICAL SPECIFICATION

- 1 Basic design and manufacture according to ANSI B16.34;
- 2 Adjustable packing gland, Bottom-loaded blow-out proof stem;
- 3 NPT Threaded ends complied with ANSI B 1.20.1;
- 4 Rc, Rp&G Threaded ends complied with BS 21/2779, DIN 259/2999, ISO 228 are upon request;
- 5 Inspection and tested according to AP1598;
- 6 Face to face according to DIN3202-M3.