

Technical Datasheet



HM P Series

Pelton Wheel Flow Meters
for monitoring heating and cooling circuits

Description

The HM P turbine flow meter series (P for Pelton Runner) is used to measure continuous and discontinuous flow rates. They are mainly used for lubrication and non-lubrication media. They are particularly suitable for low and medium viscosity liquids, such as water, light oils, emulsions and glycol mixtures.

Only high-grade steels that even withstand corrosive liquids are used in the production of turbine flow meters. Combined with the use of ceramic bearings, the HM P guarantees optimum measurement accuracy and an extremely long service life even under the toughest application conditions.

Due to the innovative design and optimized bearings, even highly contaminated and extremely hot media can be measured reliably. This predestines the HM P for use in heating and cooling circuits as well as monitoring and dosing applications.

For applications in hazardous areas, we offer intrinsically safe sensors and amplifiers with Ex protection in accordance with ATEX, IECEx, CSA and other standards. Additional certifications such as EAC (TR-CU) are available.

Principle and Design

The flow meter HM P are indirect volume counters according to the principle of the impeller meter. The energy present in a flow causes the rotatably mounted impeller to move and the number of the rotor revolutions is directly proportional to the volume flow. The speed of rotation is tapped by the contactless sensor technology (transducer) through the housing wall. The impulses generated by each turbine blade correspond to a certain accurate volumetric flow of the measured medium. The number of pulses for a certain period of time corresponds to the value of the medium flow rate expressed, for example, in litres per minute. The lightweight turbine wheel allows quick response times for flow changes (< 50 m/s). Compared to common turbine flow meters the flow meters with impeller are less sensitive to dirt.

The use of high quality design materials allows application of these flow meters up to the temperature of medium +350°C.[+662 °F]

Applications

- Monitoring of oil temperature
- Cooling water monitoring
- Process control
- Water
- Heat-carrying agents (oils to heating systems)
- Fuels
- Water-/glycol mixtures
- Heat transfer fluid

Features

- Temperature range: up to 350 °C [+662 °F]
- Suited for polluted liquids
- Stainless steel
- Ceramic bearings resistant to wearing
- Compact design
- Economical version

Technical Data – Sizes

HM Type ¹⁾	Measuring Range (l/min)		K-Factor ²⁾ (pulses/l)	max. Pressure (bar/psi)	max. Frequency ²⁾ (Hz)	Weight (kg)
HM P 09	3.0	to 30	980	20 [290]	520	0.9
HM P 12	8.5	to 85	650	20 [290]	980	0.9
HM P 17	15	to 150	309	20 [290]	770	0.9
HM P 25	28	to 280	127	20 [290]	820	1.1

Technical Data – General

Repeatability	±0.5 % (under the same conditions)
Linearity	±2.5 % of actual flow (viscosity = 1 mm ² /s)
Viscosity Range	0.8 up to 10 mm ² /s
Materials	Housing: as per DIN 1.4305 [AISI 303] Wheels: as per DIN 1.4122 Bearing: Brass, Ceramics Seals: FKM, Graphite
Medium Temperature	-60 °C up to +350 °C [-76 °F up to +662 °F]
Dimensions	See dimensional drawing (page 4)

Ordering Code

HMP - XX - XX - XX - X - XXXX

Measuring Range

3.0 - 30.0 l/min	09
8.5 - 85.0 l/min	12
15 - 150 l/min	17
28 - 280 l/min	25

Meter Attributes

Housing	Bearing	Shaft	Bolts	
1.4305 (AISI 303)	Brass	Ceramic	ISO 4017	SM
1.4305 (AISI 303)	Ceramic	Ceramic	ISO 7380	SC

Process Connection ³⁾

Line Size	Thread	
1/2"	BSPP	1/2"
3/4"	BSPP	3/4"
1"	BSPP	1"

Sensor Ports

M14x1.5	E
M10x0.75	M

Sealing Option

Material	T _{max.}	
FKM (Viton®)	+180 °C [+356 °F]	V-180
Graphite	+350 °C [+662 °F]	G-350

¹⁾ Exact type designation on request.

²⁾ Average values

³⁾ Possible connection sizes according to dimensional drawing.

Dimensional Drawing

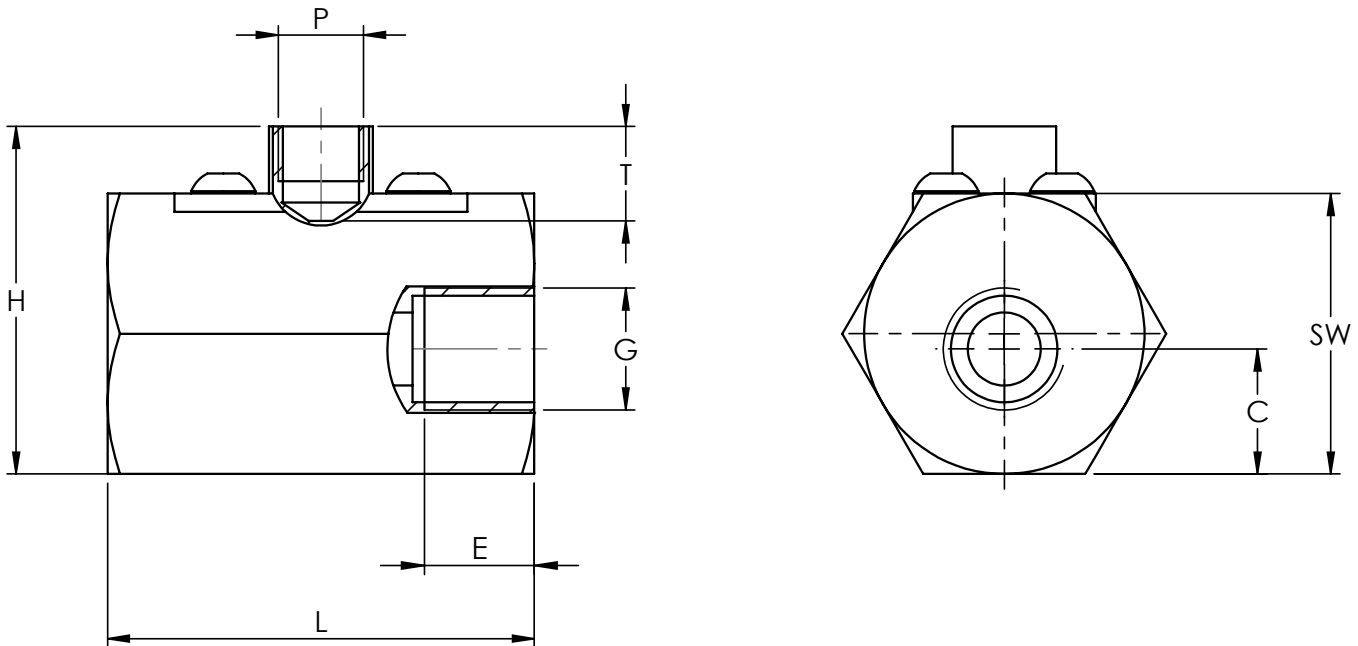

HM Type	C	E	G	H	L	P	T ⁴⁾	SW
HM P 09	20.5 mm [0.81 in]	20 mm [0.79 in]	G 1/2"	57 mm [2.24 in]	70 mm [2.75 in]	M14x1.5	16 mm [0.63 in]	46 mm [1.81 in]
HM P 12	20.5 mm [0.81 in]	20 mm [0.79 in]	G 1/2" G 3/4"	57 mm [2.24 in]	70 mm [2.75 in]	M14x1.5	16 mm [0.63 in]	46 mm [1.81 in]
HM P 17	20.5 mm [0.81 in]	20 mm [0.79 in]	G 1"	61 mm [2.40 in]	70 mm [2.75 in]	M14x1.5	16 mm [0.63 in]	50 mm [1.97 in]
HM P 25	23 mm [0.91 in]	20 mm [0.79 in]	G 1"	66 mm [2.60 in]	70 mm [2.75 in]	M14x1.5	16 mm [0.63 in]	55 mm [2.17 in]

⁴⁾ Attention: the total installation height is the result of the height (H) and the height of the electronics (dimensions in separate datasheet).

Pressure Drop Curves

HMP 09

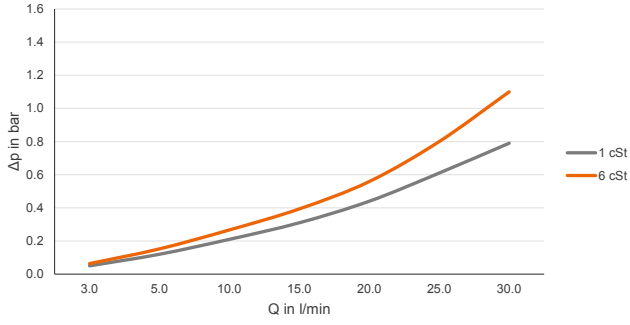

HMP 12

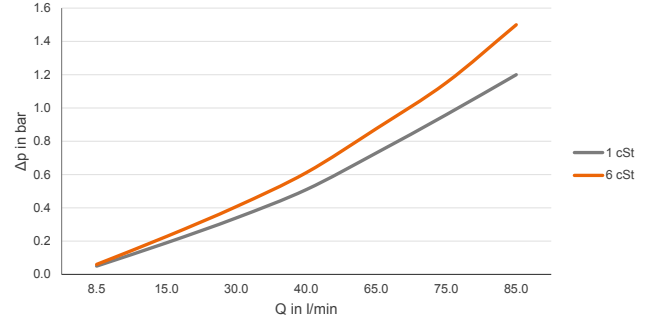

HMP 17

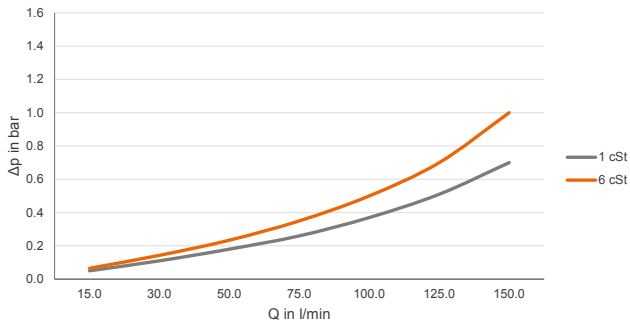

HMP 25

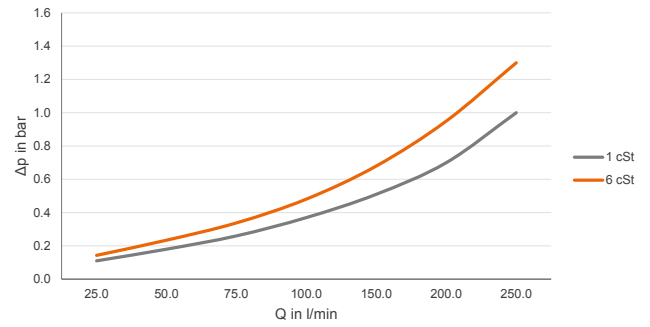

Calibration

In-house calibration is performed on volumetric calibration rigs or at the wishes of the customer in our DAkkS calibration laboratory.

The KEM calibration lab uses a high-precision load cell system. With an accuracy of 0.05 % for the mass and 0.1 % for the volume of flowing liquids, we occupy a leading position worldwide. The German Accreditation Body (DAkkS) has accredited the laboratory with engineers, processes and measuring equipment in accordance with the international standard DIN EN ISO/IEC 17025:2005.

The KEM calibration certificate not only verifies the accuracy of a flow meter, but also guarantees its traceability to national standards as well as ensuring all requirements according to international quality standards are met.

The calibrations are performed with different hydrocarbons. This ensures the optimum simulation of changing operating conditions in density and viscosity even when temperatures change. This way the primary viscosity for the use of the flow meter can be specifically taken into account when viscosity fluctuations occur in a customised application.

The calibration result is the specified calibration factor (K-factor) in pulses per litre. This K-factor accordingly applies only at a certain flow velocity or a certain flow rate.

The calibration factor varies only very slightly at different volume flow rates. The individual measuring points provide the calibration curve of the flow meter from which the average K-factor is determined. The average calibration factor applies to the entire measuring range.

The linearity error specification (percentage deviation) refers to the average K-factor. To further increase the measurement accuracy in onsite use, the specific K-factors can be used to calculate the flow rate. For this, KEM also supplies optional special electronics.

Calculation of volume flow

The flow is directly dependent on the measured frequency and the associated calibration factor:

$$Q = \frac{f \cdot 60}{K} \text{ l/min}$$

Q = Volume Flow
f = Measuring frequency
K = Specific K-Factor

Calibration protocol

Example: HM P 12

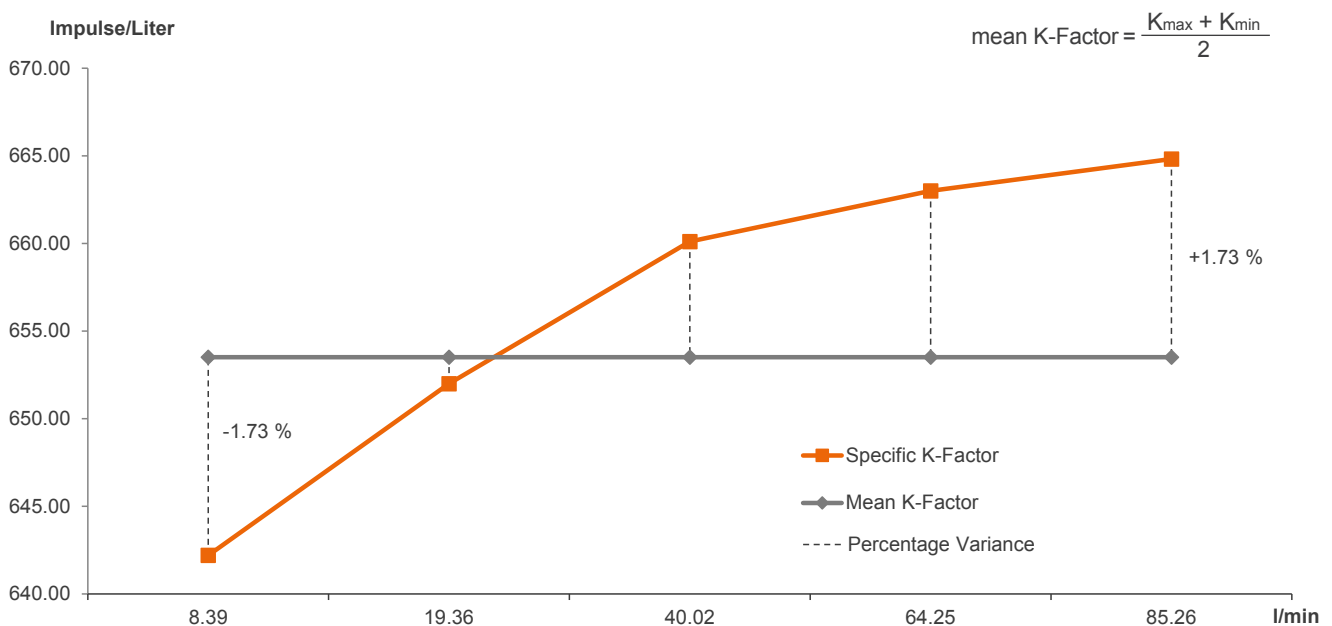



Küppers Elektromechanik GmbH

www.kem-kueppers.com

info@kem-kueppers.com

KEM Headquarters

Liebigstraße 5
85757 Karlsfeld
Germany

T. +49 8131 59391-0
F. +49 8131 92604

info@kem-kueppers.com

KEM Sales

Liebigstraße 5
85757 Karlsfeld
Germany

T. +49 8131 59391-100
F. +49 8131 92604

sales@kem-kueppers.com

KEM Manufacturing Center

Wetzeller Straße 22
93444 Bad Kötzing
Germany

T. +49 9941 9423-0
F. +49 9941 9423-23

production@kem-kueppers.com

KEM Service & Repairs

Wetzeller Straße 22
93444 Bad Kötzing
Germany

T. +49 9941 9423-37
F. +49 9941 9423-24

service@kem-kueppers.com

*More distributors & partners can be found at:
www.kem-kueppers.com*