

Technical Datasheet



HM TC-R Series

Turbine Flow Meters

for solvents and water with compact electronics

Description

The HM TC-R turbine flow meter series (TC-R for BSPP ports and compact electronics) is used to measure continuous and discontinuous flow rates. They are mainly used for flow measurement in solvents, water, detergents and light oils.

Only high-grade steels that even withstand corrosive liquids are used in the production of turbine flow meters. Combined with the use of tungsten carbide bearings, the HM TC-R guarantees optimum measurement accuracy and an extremely long service life even under the toughest application conditions.

The combination of various turbine wheel dimensions and blade geometries allows a wide range of sizes that can cover a huge measuring range. This makes the HM TC-R ideal for a variety of applications in the field of metering as well as for monitoring, mixing and dosing.

Short response times, very dynamic performance and high measurement accuracy ensure accurate regulation and control of flow rates in the most demanding applications.

For applications in hazardous areas, we offer intrinsically safe sensors and amplifiers with Ex protection in accordance with ATEX, IECEx and CSA.

Principle and Design

Turbine flow meters (HM) are volume counters operating on the Woltmann impeller counter principle. They record the flow rate in the flow-through in a pipe via the average flow velocity.

The flow of the medium is directed at the turbine wheel in the axial direction and so rotated. The speed of the freely turning wheel over a wide range is directly proportional to the average flow velocity. The low weight of the turbine wheel ensures very short response times as well as very dynamic behaviour in flow changes. Two flow straighteners generate quasi-laminar flow, which in turn contributes to increasing the measurement accuracy.

The speed of the turbine wheel is tapped by the contactless sensor technology (transducer) through the housing wall. Pulses per unit of volume are available for analysis. The calibration factor (K-factor) of the flow meter describes the exact pulse rate per unit of volume. In order to determine the individual calibration factor of a flow meter, we calibrate each of our meters in house prior to delivery. The operating viscosity specified by the customer is taken into account for calibration. A corresponding calibration certificate is included with every flow meter we supply.

The KEM turbines feature a short response time between 5 and 50 ms depending on the nominal width, which is advantageous for precise filling processes.

Turbine flow meters have a resolution of up to 100,000 pulses per litre. The milled and turned precision components are the reason why the HM series has neither wetted weld seams nor soldered connections. All market-related requirements for piping and material standards can thus be fully guaranteed.

Applications

- Solvents
- Water
- Alcohol
- Fuels
- Detergents
- Light oils

Features

- High measuring accuracy up to $\pm 0.1\%$ ¹⁾
- Exceptional repeatability of $\pm 0.05\%$
- Compact Design
- Short response times (from 5 ms)
- Robust carbide bearing
- Pressure stage up to 630 bar [9,137 psi]
- Ex protection according to ATEX 100/IEC Ex/CSA

¹⁾ Under laboratory conditions; incl. linearization; viscosity $\geq 1\text{ mm}^2/\text{s}$.

Technical Data – Sizes

HM Type ²⁾	Measuring Range (l/min)		K-Factor ³⁾ (pulses/l)	max. Pressure (bar/psi)	max. Frequenz ³⁾ (Hz)	Weight (kg)
HM 003 TC-R	0.3	to 1.5	32,500	630 [9,317]	1,100	0.8
HM 004 TC-R	0.5	to 4	24,000	630 [9,317]	1,700	0.8
HM 005 TC-R	0.8	to 6	17,800	630 [9,317]	1,700	0.9
HM 006 TC-R	1.2	to 10	12,000	630 [9,317]	2,100	0.9
HM 007 TC-R	2.0	to 20	5,200	630 [9,317]	1,800	0.9
HM 013 TC-R	8.5	to 85	900	400 [5,800]	1,300	2.1

Technical Data – General

Measuring Accuracy	±0.1 % ⁴⁾
Repeatability	±0.05 % (under the same conditions)
Linearity	±1 % of actual flow
Viscosity Range	1 mm ² /s
Materials	Housing: as per DIN 1.4305 [AISI 303] Wheels: as per 1.4460 [AISI 329] Bearing: Tungsten carbide sleeve bearing
Medium Temperature	T3: -40 °C up to +80 °C [-40 °F up to +176 °F] T4: -40 °C up to +60 °C [-40 °F up to +140 °F]
Dimensions	See dimensional drawing (page 4)

Safety specifications

Supply circuit Pin 1, 2 and 3	$U_i = 30 \text{ V DC}$ $I_i = 120 \text{ mA}$ $P_i = 850 \text{ mW}$ $C_i = 8 \text{ nF}$ $L_i = 5 \mu\text{H}$
Supply circuit Pin 3 and 4	$U_i = 30 \text{ V DC}$ $I_i = 24,6 \text{ mA}$ $P_i = 185 \text{ mW}$ $C_i = 8 \text{ nF}$ $L_i = 5 \mu\text{H}$

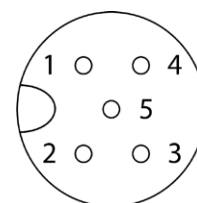

M12 socket plug (5-pin, female, A-coded)

Pinout

Typ	Pin 1	Pin 2	Pin 3	Pin 4	Pin 5
P/P	+U _B	GND	GND	f _{out}	PE
NAMUR	+U _B	OV/GND	—	—	—

²⁾ Exact type designation on request.

³⁾ Average values for single sensors at viscosity of 1 mm²/s; higher viscosities may differ.

⁴⁾ Under laboratory conditions; incl. linearization; viscosity ≥1 mm²/s.

Dimensional Drawing

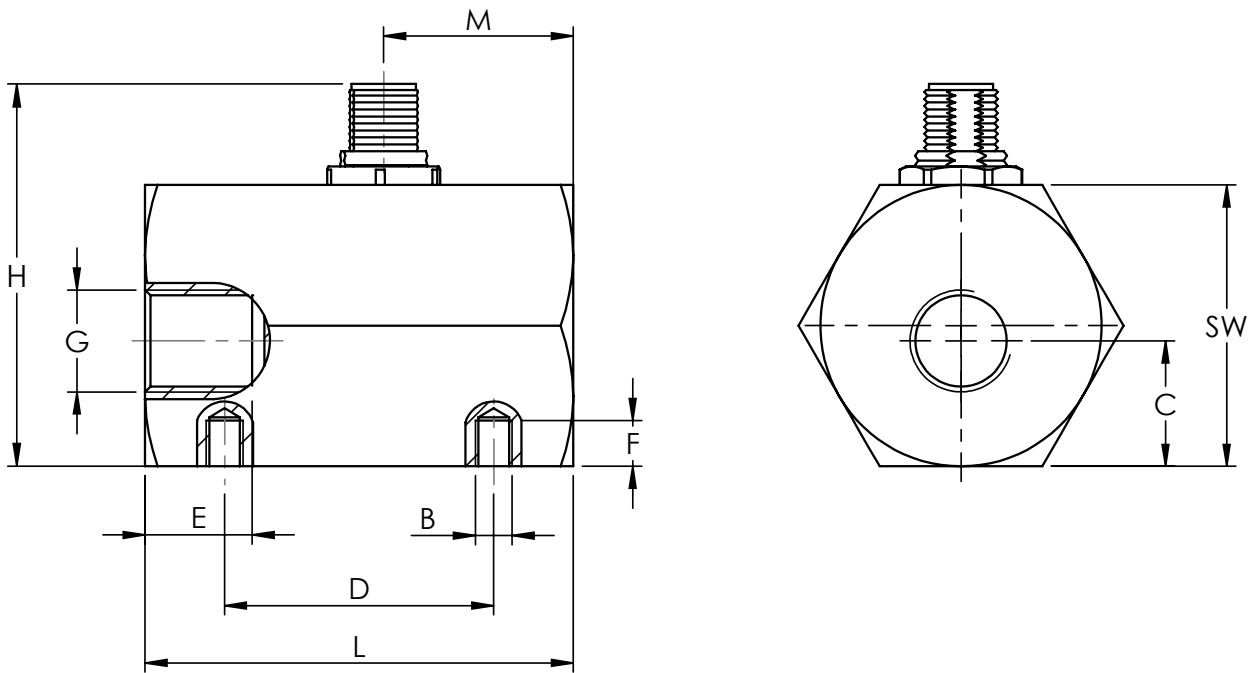

HM Type	B	C	D	E	F	G	H	L	M	SW
HM 003 TC-R	M6	20.5 mm [0.81 in]	44 mm [1.73 in]	14 mm [0.55 in]	7.5 mm [0.30 in]	G $\frac{1}{4}$ "	62.5 mm [2.46 in]	63 mm [2.48 in]	24 mm [0.94 in]	46 mm [1.81 in]
HM 004 TC-R	M6	20.5 mm [0.81 in]	44 mm [1.73 in]	14 mm [0.55 in]	7.5 mm [0.30 in]	G $\frac{1}{4}$ "	62.5 mm [2.46 in]	63 mm [2.48 in]	24 mm [0.94 in]	46 mm [1.81 in]
HM 005 TC-R	M6	20.5 mm [0.81 in]	44 mm [1.73 in]	14 mm [0.55 in]	7.5 mm [0.30 in]	G $\frac{3}{8}$ "	62.5 mm [2.46 in]	70 mm [2.76 in]	28 mm [1.10 in]	46 mm [1.81 in]
HM 006 TC-R	M6	20.5 mm [0.81 in]	44 mm [1.73 in]	14 mm [0.55 in]	7.5 mm [0.30 in]	G $\frac{3}{8}$ "	62.5 mm [2.46 in]	70 mm [2.76 in]	28 mm [1.10 in]	46 mm [1.81 in]
HM 007 TC-R	M6	20.5 mm [0.81 in]	44 mm [1.73 in]	14 mm [0.55 in]	7.5 mm [0.30 in]	G $\frac{3}{8}$ "	62.5 mm [2.46 in]	74 mm [2.91 in]	30 mm [1.18 in]	46 mm [1.81 in]
HM 013 TC-R	M6	30 mm [1.18 in]	44 mm [1.73 in]	16 mm [0.63 in]	10 mm [0.38 in]	G $\frac{3}{4}$ "	77.5 mm [3.05 in]	97 mm [3.82 in]	32 mm [1.26 in]	60 mm [2.36 in]

Ordering Code

	HM	XX	-	X	-	XX	-	XX	-	XXX	-	Ex
Bearing		TC										
Tungsten carbide sleeve bearing		TC										
Process connection				R								
Female Inch Threads				R								
Housing Material						S01						
Stainless steel						S01						
Electric connection								TF				
Integrated carrier frequency amplifier								TF				
Scaling factor										001		
Scaling factor 1:1										001		
Scaling factor 1:4										004		
max. <500 Hz frequency output										500		
Ex Protection												Ex
ATEX II 2G Ex ia IIC T4, IEC E, CSA												Ex
ATEX II 3G Ex nA IIC T4												Exn



Calibration

In-house calibration is performed on volumetric calibration rigs or at the wishes of the customer in our DAkkS calibration laboratory.

The KEM calibration lab uses a high-precision load cell system. With an accuracy of 0.05 % for the mass and 0.1 % for the volume of flowing liquids, we occupy a leading position worldwide. The German Accreditation Body (DAkkS) has accredited the laboratory with engineers, processes and measuring equipment in accordance with the international standard DIN EN ISO/IEC 17025:2005.

The KEM calibration certificate not only verifies the accuracy of a flow meter, but also guarantees its traceability to national standards as well as ensuring all requirements according to international quality standards are met.

The calibrations are performed with different hydrocarbons. This ensures the optimum simulation of changing operating conditions in density and viscosity even when temperatures change. This way the primary viscosity for the use of the flow meter can be specifically taken into account when viscosity fluctuations occur in a customised application.

The calibration result is the specified calibration factor (K-factor) in pulses per litre. This K-factor accordingly applies only at a certain flow velocity or a certain flow rate.

The calibration factor varies only very slightly at different volume flow rates. The individual measuring points provide the calibration curve of the flow meter from which the average K-factor is determined. The average calibration factor applies to the entire measuring range.

The linearity error specification (percentage deviation) refers to the average K-factor. To further increase the measurement accuracy in onsite use, the specific K-factors can be used to calculate the flow rate. For this, KEM also supplies optional special electronics.

Calculation of volume flow

The flow is directly dependent on the measured frequency and the associated calibration factor:

$$Q = \frac{f \cdot 60}{K} \text{ l/min}$$

Q = Volume Flow

f = Measuring frequency

K = Specific K-Factor

Calibration protocol

Example: HM 007 TC-R

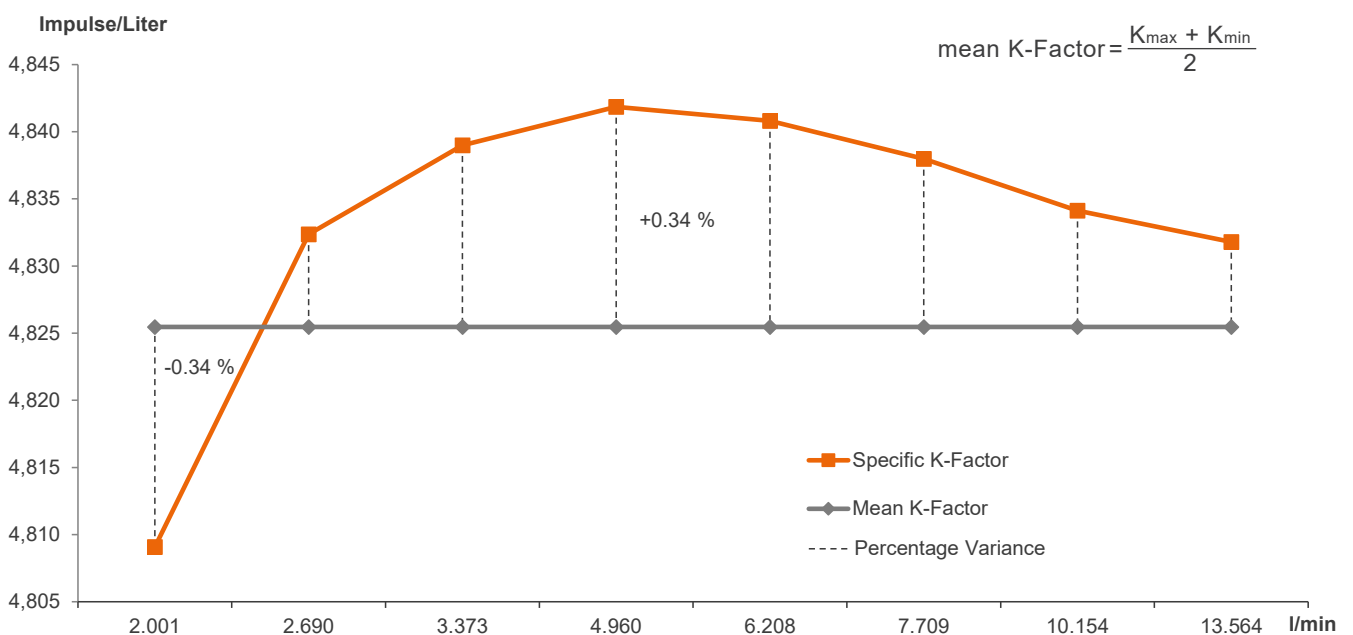



Küppers Elektromechanik GmbH

www.kem-kueppers.com

info@kem-kueppers.com

KEM Headquarters

Liebigstraße 5
85757 Karlsfeld
Germany

T. +49 8131 59391-0
F. +49 8131 92604

info@kem-kueppers.com

KEM Manufacturing Center

Wetzeller Straße 22
93444 Bad Kötzing
Germany

T. +49 9941 9423-0
F. +49 9941 9423-23

production@kem-kueppers.com

KEM Sales

Liebigstraße 5
85757 Karlsfeld
Germany

T. +49 8131 59391-100
F. +49 8131 92604

sales@kem-kueppers.com

KEM Service & Repairs

Wetzeller Straße 22
93444 Bad Kötzing
Germany

T. +49 9941 9423-37
F. +49 9941 9423-24

service@kem-kueppers.com

*More distributors & partners can be found at:
www.kem-kueppers.com*