

Technical Datasheet

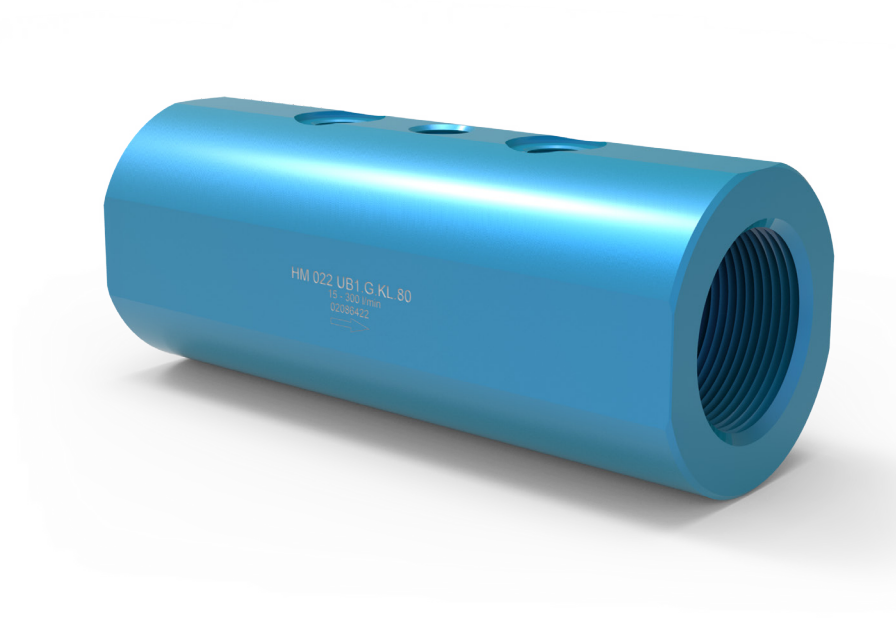

HM U Series

Turbine Flow Meters
for lubricating liquids

Description

The HM U turbine flow meter series (U for aluminum housing and ball bearing) is used to measure continuous and discontinuous flow rates. They are mainly used for lubrication media. They are particularly suitable for low and medium viscosity liquids, such as hydraulic oil, glycol mixtures and emulsions. Even the measurement of cryogenic fluids is possible. For pressure and temperature measuring, standard connection threads are provided in the housing.

Only high-strength aluminum, quality materials and stainless steel ball bearings, that even withstand corrosive liquids, are used in the production of turbine flow meters. This guarantees optimum measurement accuracy and an extremely long service life even under the toughest application conditions.

The combination of various turbine wheel dimensions and blade geometries allows a wide range of sizes that can cover a huge measuring range. This makes the HM U ideal for a variety of applications in the field of monitoring and consumption measurement.

Short response times, very dynamic performance and high measurement accuracy ensure accurate regulation and control of flow rates in the most demanding applications.

For applications in hazardous areas, we offer intrinsically safe sensors and amplifiers with Ex protection in accordance with ATEX, IECEx, CSA and other standards. Additional certifications such as EAC (TR-CU) are available.

Principle and Design

Turbine flow meters (HM) are volume counters operating on the Woltmann impeller counter principle. They record the flow rate in the flow-through in a pipe via the average flow velocity.

The flow of the medium is directed at the turbine wheel in the axial direction and so rotated. The speed of the freely turning wheel over a wide range is directly proportional to the average flow velocity. The low weight of the turbine wheel ensures very short response times as well as very dynamic behaviour in flow changes. Two flow straighteners generate quasi-laminar flow, which in turn contributes to increasing the measurement accuracy.

The speed of the turbine wheel is tapped by the contactless sensor technology (transducer) through the housing wall. The sensor system can be variably adapted to meet the requirements of the respective application.

Pulses per unit of volume are available for analysis. The calibration factor (K-factor) of the flow meter describes the exact pulse rate per unit of volume. In order to determine the individual calibration factor of a flow meter, we calibrate each of our meters in house prior to delivery. The operating viscosity specified by the customer is taken into account for calibration. A corresponding calibration certificate is included with every flow meter we supply.

The KEM turbines feature a short response time less than 50 milliseconds. The milled and turned precision components are the reason why the HM series has neither wetted weld seams nor soldered connections. All market-related requirements for piping and material standards can thus be fully guaranteed.

Applications

- Hydraulic oil
- Glycol mixture
- Emulsions
- Test oils
- Hydraulic system monitoring
- Test stands
- Mobile hydraulic measurement

Features

- Operating pressure up to 420 bar [6.092 psi]
- High strength aluminum housing
- Stainless steel ball bearing
- inner parts made of stainless steel
- Pressure and temperature connections
- Low weight

Technical Data – Sizes

HM Type ¹⁾	Measuring Range (l/min)		K-Factor ²⁾ (pulses/l)	max. Pressure (bar/psi)	max. Frequency ²⁾ (Hz)	Weight (kg)
HM 007 U	1.2	to 20	4,800	420 [6,090]	1,800	0.6
HM 011 U	6	to 60	2,800	420 [6,090]	1,350	0.7
HM 022 U	15	to 300	605	420 [6,090]	800	1.3
HM 030 U	40	to 600	204	420 [6,090]	860	1.4

Technical Data – General

Measuring Accuracy	±0.5 % ³⁾
Repeatability	±0.5 % (under the same conditions)
Linearity	±2.5 % of actual flow
Viscosity Range	30 mm ² /s
Materials	Housing: as per DIN 3.4365 [EN AW-7075] Inner parts: as per DIN 1.4305 [AISI 303] Wheels: as per DIN 1.4122 Bearing: HM 007 - 011: Tungsten carbide sleeve bearing HM 022 - 030: Stainless steel ball bearing
Medium Temperature	-40 °C up to +120 °C [-40 °F up to +248 °F]
Dimensions	See dimensional drawing (page 4)

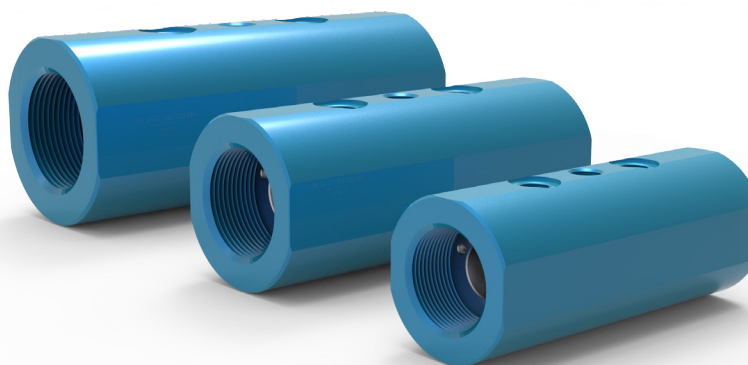

¹⁾ Exact type designation on request.

²⁾ Average values for single sensors at viscosity of 1 mm²/s; higher viscosities may differ.

³⁾ Under laboratory conditions; incl. linearization; viscosity = 30 mm²/s.

Dimensional Drawing

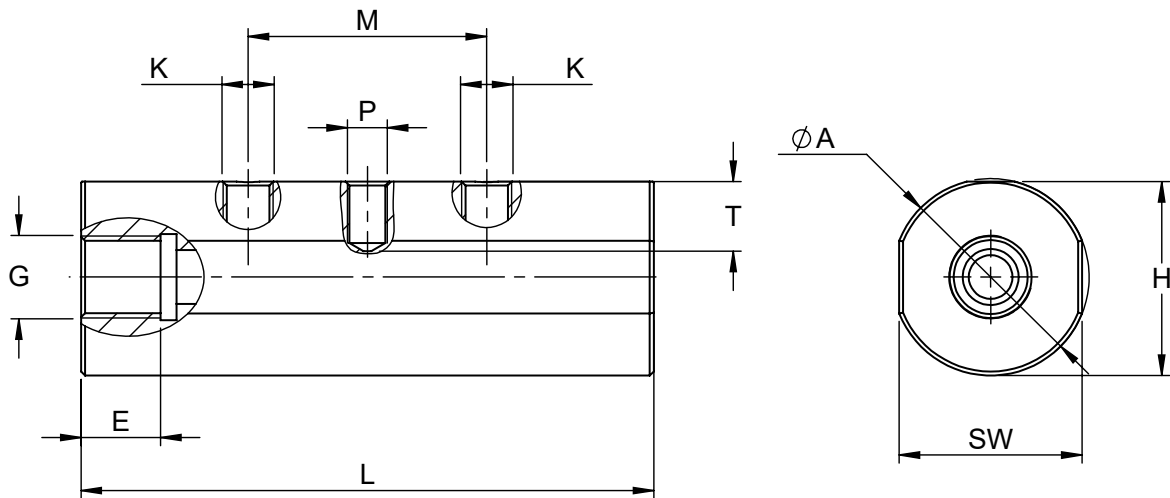

HM Type	Ø A	E	G	H	K	L	M	P	T ³⁾	SW	Ermeto Adapter
HM 007 U	50 mm [1.97 in]	16 mm [0.63 in]	G 1/4"	47.5 mm [1.87 in]	G 1/4"	117 mm [4.61 in]	60 mm [2.36 in]	M14x1.5	18 mm [0.71 in]	46 mm [1.81 in]	GE 08 SREDOMD
HM 011 U	50 mm [1.97 in]	19 mm [0.75 in]	G 1/2"	49 mm [1.93 in]	G 1/4"	144 mm [5.67 in]	60 mm [2.36 in]	M14x1.5	18 mm [0.71 in]	46 mm [1.81 in]	GE 16 SREDOMD
HM 022 U	65 mm [2.56 in]	30 mm [1.18 in]	G 1 1/4"	64 mm [2.52 in]	G 1/4"	155 mm [6.10 in]	60 mm [2.36 in]	M14x1.5	19 mm [0.75 in]	60 mm [2.36 in]	GE 30 SREDOMD
HM 030 U	65 mm [2.56 in]	30 mm [1.18 in]	G 1 1/2"	64 mm [2.52 in]	G 1/4"	181 mm [7.13 in]	60 mm [2.36 in]	M14x1.5	15 mm [0.59 in]	60 mm [2.36 in]	GE 38 SREDOMD

³⁾ Attention: the total installation height is the result of the height (H) and the height of the electronics (dimensions in separate datasheet).

Calibration

In-house calibration is performed on volumetric calibration rigs or at the wishes of the customer in our DAkkS calibration laboratory.

The KEM calibration lab uses a high-precision load cell system. With an accuracy of 0.05 % for the mass and 0.1 % for the volume of flowing liquids, we occupy a leading position worldwide. The German Accreditation Body (DAkkS) has accredited the laboratory with engineers, processes and measuring equipment in accordance with the international standard DIN EN ISO/IEC 17025:2005.

The KEM calibration certificate not only verifies the accuracy of a flow meter, but also guarantees its traceability to national standards as well as ensuring all requirements according to international quality standards are met.

The calibrations are performed with different hydrocarbons. This ensures the optimum simulation of changing operating conditions in density and viscosity even when temperatures change. This way the primary viscosity for the use of the flow meter can be specifically taken into account when viscosity fluctuations occur in a customised application.

The calibration result is the specified calibration factor (K-factor) in pulses per litre. This K-factor accordingly applies only at a certain flow velocity or a certain flow rate.

The calibration factor varies only very slightly at different volume flow rates. The individual measuring points provide the calibration curve of the flow meter from which the average K-factor is determined. The average calibration factor applies to the entire measuring range.

The linearity error specification (percentage deviation) refers to the average K-factor. To further increase the measurement accuracy in onsite use, the specific K-factors can be used to calculate the flow rate. For this, KEM also supplies optional special electronics.

Calculation of volume flow

The flow is directly dependent on the measured frequency and the associated calibration factor:

$$Q = \frac{f \cdot 60}{K} \text{ l/min}$$

- Q = Volume Flow
- f = Measuring frequency
- K = Specific K-Factor

Calibration protocol

Example: HM 030 U

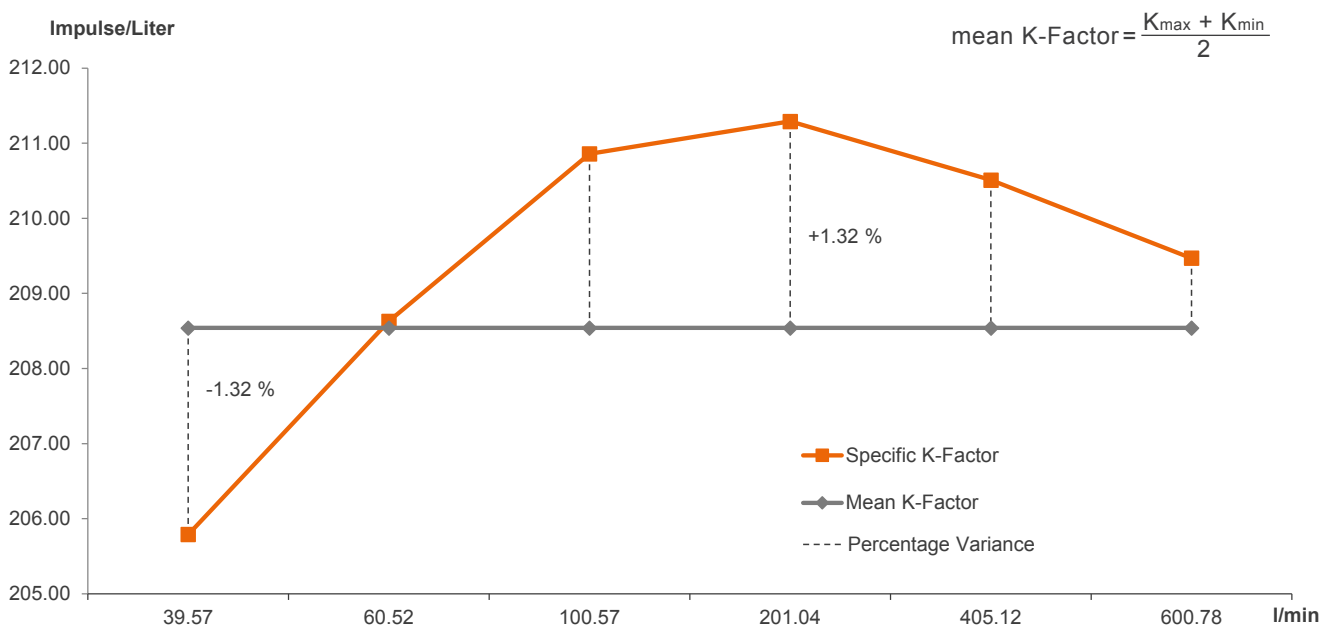



Küppers Elektromechanik GmbH

www.kem-kueppers.com

info@kem-kueppers.com

KEM Headquarters

Liebigstraße 5
85757 Karlsfeld
Germany

T. +49 8131 59391-0
F. +49 8131 92604

info@kem-kueppers.com

KEM Sales

Liebigstraße 5
85757 Karlsfeld
Germany

T. +49 8131 59391-100
F. +49 8131 92604

sales@kem-kueppers.com

KEM Manufacturing Center

Wetzeller Straße 22
93444 Bad Kötzing
Germany

T. +49 9941 9423-0
F. +49 9941 9423-23

production@kem-kueppers.com

KEM Service & Repairs

Wetzeller Straße 22
93444 Bad Kötzing
Germany

T. +49 9941 9423-37
F. +49 9941 9423-24

service@kem-kueppers.com

*More distributors & partners can be found at:
www.kem-kueppers.com*